

## LARGE BORE

MALE SERIES

FEMALE SERIES

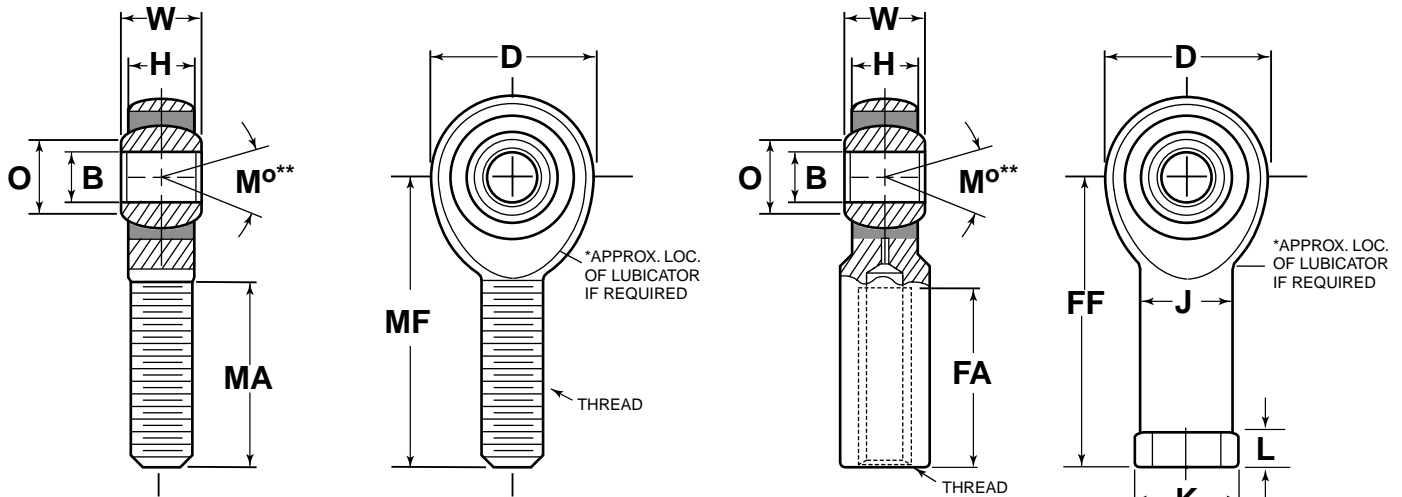

RM

Male

RADIAL PART NO.	B	W	H	O	MF	D	Ball Dia.	MA	Thread	M°**	Max. Static Radial Load (LBS)		Approx. Weight (LBS)
											RM	RM-H	
MALE	+0.0000 -0.0005	+0.000 -0.005	±0.010	(REF.)	±0.020	+0.030 -0.010	(REF.)	+0.062 -0.031	CLASS UNF-3A	misalign angle	RM	RM-H	
RM-20	1.2500	1.093	.937	1.423	4.125	2.750	1.795	2.125	1 1/4-12	7.0	44,500	79,728	2.406
RM-24	1.5000	1.312	1.125	1.710	5.375	3.500	2.155	3.000	1 1/2-12	6.5	64,770	138,826	4.75
RM-32	2.0000	1.750	1.500	2.281	8.000	5.000	2.875	4.625	2 - 12	6.0	153,528	364,655	14.25

RF

Female

RADIAL PART NO.	B	W	H	O	FF	D	K	J	L	Ball Dia.	FA	Thread	M°**	Max. Static Radial Load in Pounds		Approx. Weight in Pounds
														RF	RF-H	
FEMALE	+0.0000 -0.0005	+0.000 -0.005	±0.010	(REF.)	±0.020	+0.030 -0.010	±0.030	±0.030	±0.030	(REF.)	+0.062 -0.031	CLASS UNF-2B	misalign angle	RF	RF-H	
RF-20	1.2500	1.093	.937	1.423	4.125	2.750	1.625	1.500	.500	1.795	2.125	1 1/4-12	7.0	44,500	79,728	2.125
RF-24	1.5000	1.312	1.125	1.710	5.375	3.500	2.250	2.000	.875	2.155	2.625	1 1/2-12	6.5	64,770	138,826	6.50
RF-32	2.0000	1.750	1.500	2.281	8.000	5.000	3.125	2.750	1.000	2.875	4.000	2 - 12	6.0	153,528	364,655	15.00

## Materials

DESIGNATION	BALL	RACE	BODY
Basic Part No.	52100 Steel Heat Treated MOS <sub>2</sub> Coated	52100 Steel Heat Treated MOS <sub>2</sub> Coated	Low Carbon Steel-Cad or Zinc Plated
Basic Part No. & "H"			Alloy Steel Heat Treated Cadmium or Zinc Plated

\*A trade name of E. I. Dupont de Nemours & Co.

## Notes

1. Add letter "L" to prefix to indicate left hand threads. Example: RML-20.
2. Optional lubricators available. Add "Z" to suffix to indicate zerk type lubricator. Add "F" to suffix to indicate flush type lubricator. Example: RM-20Z, RF-20HF
3. Load ratings do not include effect of lubricators, consult with Radial Engineering Dept. for load ratings with lubricators.
4. Special sizes and materials can be furnished upon request.
5. \*Teflon Liner available upon request.
- \*\*6. M° equals total included misalignment angle for clevis mounted rod end

