



RADIAL BEARING CORPORATION



Aircraft Quality
Rod End & Spherical Bearings

INTRODUCTION

...BIG ENOUGH TO SERVE, SMALL ENOUGH TO CARE.

Radial Bearing Corporation was founded in 1955 with the objective of producing and marketing quality products serving the military and commercial aircraft sectors.

Today, we offer a broad line of standard spherical and rod end bearings, as well as a variety of speciality bearings designed and manufactured to your specific requirements.

Our Quality Management System is registered to **AS9100/ISO 9001 (Design Included)** upholding our commitment to total customer satisfaction and continuous improvement.

We welcome your inquiries regarding both our standard product line and your special product needs.

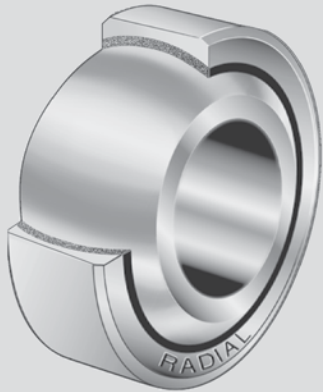

ROD ENDS

Radial Bearing rod ends are constructed using the three-piece style, consisting of a body, ball, and race. This design offers flexibility in that many different types of metals can be substituted, depending on the end user's special application.

SPHERICAL BEARINGS

Radial Bearing spherical bearings are manufactured using a one-piece race type construction. Lubrication grooves and holes at 180° provide a ready means of re-lubrication after installation. Various metals can be substituted for special applications.

SELF-LUBRICATING ROD ENDS AND SPHERICAL BEARINGS

We also offer self-lubricating polytetrafluoroethylene (PTFE) fabric liners on most of our rod ends and spherical bearing series. These self-lubricating bearings are specifically designed to eliminate the need for grease re-lubrication within a temperature range of -65° to +300°F on normal applications. This liner provides improved frictional characteristics and never requires lubrication. When temperatures are expected to exceed the range shown or applications involve high loading, vibration or high surface speed, please consult our engineering department for other available liners.

CUSTOM APPLICATIONS

If your needs are not met by our standard product line, our engineering department is ready to work with you on your special design requirements, utilizing a wide variety of combinations of materials for bearing components.

Radial has many years of experience in finding sound, economical solutions to your requirements. In many instances we will design and manufacture the completed assembly; in others, the fabricated housing is supplied by the customer, and we add the bearing components.

Introduction

RADIAL Rod End Bearings

PRECISION SERIES

RM/RF	General Purpose Precision	2
RM/RF, RM-H/RF-H, RM-T/RF-T, RM-TH/RF-TH	Large Bore Rod Ends, Metal to Metal and PTFE Lined	3
RM-T/RF-T	General Purpose Precision, PTFE Lined	4
RM-H/RF-H	High Strength Precision	5
RM-TH/RF-TH	High Strength Precision, PTFE Lined	6
XRM/XRM-H	Heavy Duty Shank	7
XRM-T/XRM-TH	Heavy Duty Shank, PTFE Lined	8
REMX	Extra Capacity	9

AEROSPACE SERIES

REM-TH-5/-6	Male, High Strength, PTFE Lined	10
REF-TH-5/-6	Female, High Strength, PTFE Lined	11
XRM-TH-5/-6	Male, PTFE Lined, Hvy Dty Shank, High Perf.	12
XRF-TH-5/-6	Female, PTFE Lined, Hvy Dty Shank, High Perf.	13
RMYT-H	Male, PTFE Lined, High Misalignment	14

RADIAL Spherical Bearings

COMMERCIAL SERIES

CRS	Commercial	15
RW/RW-V	Wide Standard Series	16-17
R, RB, RS, RSS, RCR, R-SS	Precision Metal to Metal series	18
RSH	Heavy Duty	19

AEROSPACE SERIES

RPHT/RPHT-V	Narrow, PTFE Lined	20
RWT/RWT-V	Wide PTFE Lined	21
RYT/RYT-V	High Misalignment, PTFE Lined	22
	Bearing Interchange List	23
	Engineering Data	24
	Bearing Classification Chart & General Info	25



ROD END BEARINGS/METAL TO METAL

MALE SERIES

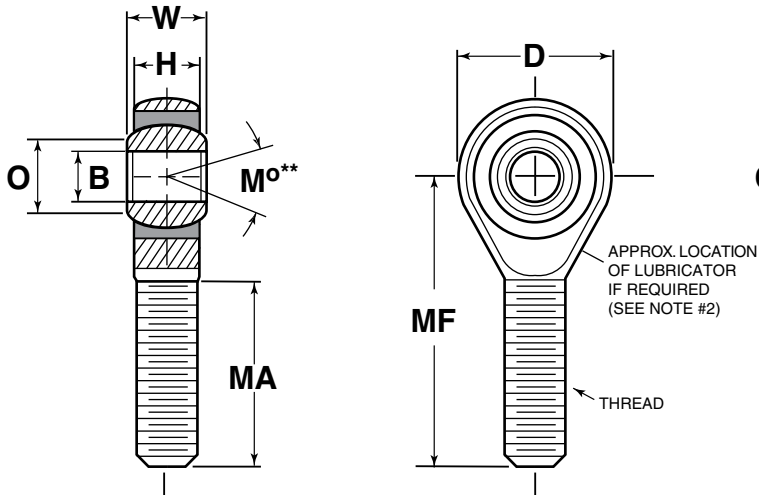

FEMALE SERIES

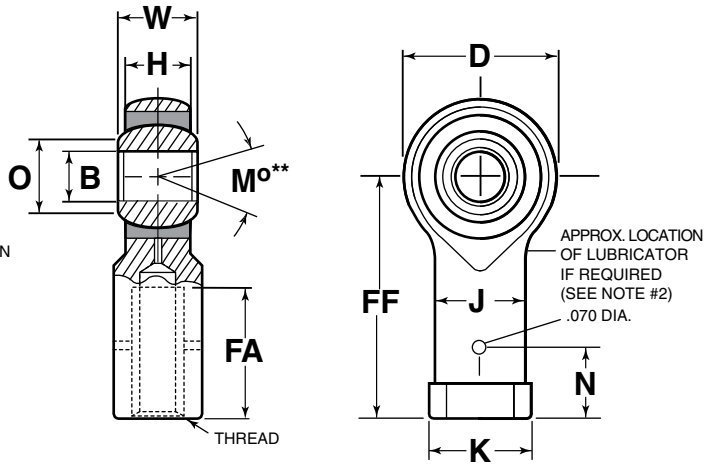

RM / RF RMX / RFX (Wear Resistant)

General Purpose Precision

RADIAL PART NO.		B	W	H	O	D	MF	FF	MA	FA	N	K	J	Ball Dia.	Thread	** M° mis align angle	Max Static Radial Load (LBS)		Approx. Weight (LBS)	
Male	Female	+0.0015 -0.0005	+0.000 -0.005	±.005	(REF.)	±.010	±.010	±.010	+1/16 -1/32	+1/16 -1/32	±.020	±.010	±.010	(REF.)	CLASS UNF-3		Male	Female	Male	Female
RM-3	RF-3	.1900	.312	.250	.264	.625	1.250	1.062	.750	.562	.312	.406	.312	.406	10-32	13	1,169	1531	.028	.038
RM-4	RF-4	.2500	.375	.281	.331	.750	1.562	1.312	1.000	.750	.312	.468	.375	.500	1/4-28	16	2,158	2,539	.043	.059
RM-5	RF-5	.3125	.437	.344	.428	.875	1.875	1.375	1.250	.750	.406	.500	.437	.610	5/16-24	14	2,784	3,133	.072	.092
RM-6	RF-6	.3750	.500	.406	.517	1.000	1.938	1.625	1.250	.937	.469	.687	.562	.718	3/8-24	12	3,915	3,915	.112	.152
RM-7	RF-7	.4375	.562	.437	.586	1.125	2.125	1.812	1.375	1.062	.531	.750	.625	.812	7/16-20	14	4,218	4,218	.160	.198
RM-8	RF-8	.5000	.625	.500	.656	1.312	2.438	2.125	1.500	1.187	.594	.875	.750	.906	1/2-20	12	6,660	6,660	.249	.320
RM-10	RF-10	.6250	.750	.562	.821	1.500	2.625	2.500	1.625	1.500	.750	1.000	.875	1.110	5/8-18	16	7,364	7,364	.382	.477
RM-12	RF-12	.7500	.875	.687	.937	1.750	2.875	2.875	1.750	1.750	.875	1.125	1.000	1.281	3/4-16	14	11,518	11,518	.602	.723
* RM-16	RF-16	1.000	1.375	1.000	1.269	2.750	4.125	4.125	2.125	2.125	-	1.625	1.500	1.875	1 1/4-12	17	43,540	43,540	2.41	2.13
* RM-16-2	RF-16-2	1.000	1.375	1.000	1.269	2.750	4.125	4.125	2.125	2.125	-	1.625	1.500	1.875	1-14	17	43,540	43,540	2.13	2.41
* RM-16-3	RF-16-3	1.000	1.375	1.000	1.269	2.750	4.125	4.125	2.125	2.125	-	1.625	1.500	1.875	1-12	17	43,540	43,540	2.13	2.41

Materials

DESIGNATION	BALL	RACE	BODY
Basic Part No.	52100 Steel	Low Carbon Steel	Low Carbon Steel
Basic Part No. & "X" Added to Prefix	Heat Treated	Cadmium or Zinc Plated	Cadmium or Zinc Plated
	Hard Chrome Plated	Alloy Steel, Heat Treated & Cadmium or Zinc Plated or Heat Treated Stainless Steel	Cadmium or Zinc Plated

Notes

1. Add letter "L" to prefix to indicate left hand threads. Example: RML-6, RFL-6
2. Optional lubricators available on sizes 4-16 only. Add "Z" to suffix to indicate zerk type lubricator. Add "F" to suffix for flush type lubricator. Example: RM-6Z, RF-6Z.
3. Load ratings do not include effect of lubricators, consult with Radial Engineering Dept. for load ratings with lubricators.
4. Special sizes and materials can be furnished upon request. For brass races specify REM/REF.
- *5 Tolerances for -16: "D" +.030, "H" ±.010, "FF" & "MF" ±.020
-.010
- **6. M° equals total included misalignment angle for clevis mounted rod end



LARGE BORE

MALE SERIES

FEMALE SERIES

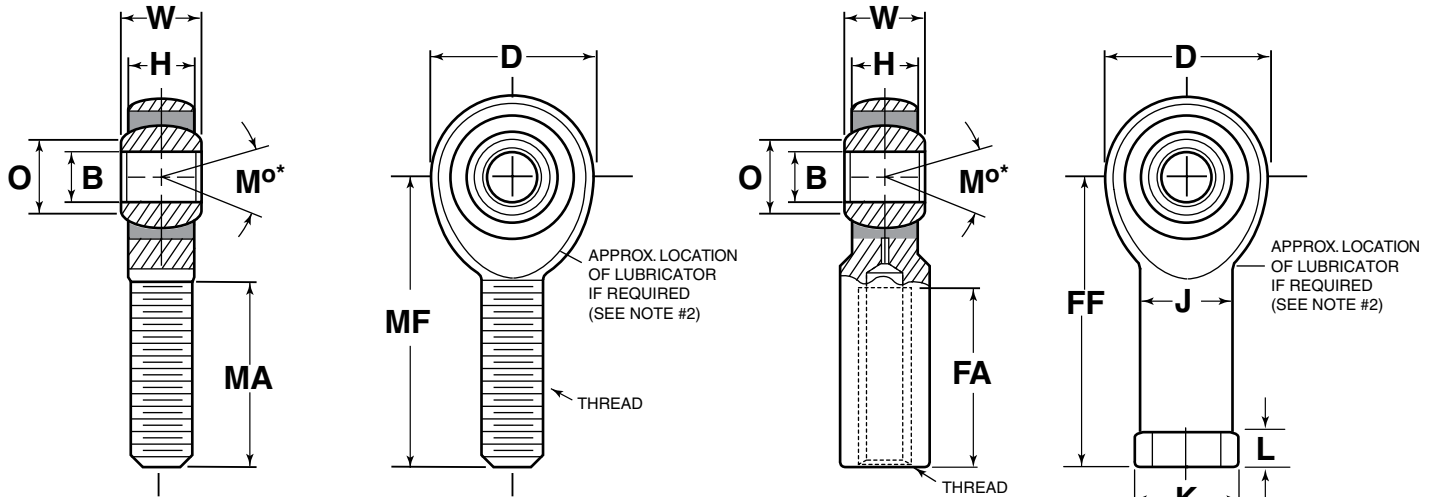

RM / RM-H / RM-T / RM-TH

Male

RADIAL PART NO.	B	W	H	O	MF	D	Ball Dia.	MA	Thread	M°*	Max. Static Radial Load (LBS)		Approx. Weight (LBS)
											RM	RM-H	
MALE	+0.0000 -0.0005	+0.000 -0.005	±0.010	(REF.)	±0.020	+0.030 -0.010	(REF.)	+0.062 -0.031	CLASS UNF-3A	misalign angle			
RM-20	1.2500	1.093	.937	1.423	4.125	2.750	1.795	2.125	1 1/4-12	7.0	44,500	79,728	2.406
RM-24	1.5000	1.312	1.125	1.710	5.375	3.500	2.155	3.000	1 1/2-12	6.5	64,770	138,826	4.75
RM-32	2.0000	1.750	1.500	2.281	8.000	5.000	2.875	4.625	2 - 12	6.0	153,528	364,655	14.25

RF / RF-H / RF-T / RF-TH

Female

RADIAL PART NO.	B	W	H	O	FF	D	K	J	L	Ball Dia.	FA	Thread	M°*	Max. Static Radial Load in Pounds		Approx. Weight in Pounds
														RF	RF-H	
FEMALE	+0.0000 -0.0005	+0.000 -0.005	±0.010	(REF.)	±0.020	+0.030 -0.010	±0.030	±0.030	±0.030	(REF.)	+0.062 -0.031	CLASS UNF-2B	misalign angle			
RF-20	1.2500	1.093	.937	1.423	4.125	2.750	1.625	1.500	.500	1.795	2.125	1 1/4-12	7.0	44,500	79,728	2.125
RF-24	1.5000	1.312	1.125	1.710	5.375	3.500	2.250	2.000	.875	2.155	2.625	1 1/2-12	6.5	64,770	138,826	6.50
RF-32	2.0000	1.750	1.500	2.281	8.000	5.000	3.125	2.750	1.000	2.875	4.000	2 - 12	6.0	153,528	364,655	15.00

Materials

DESIGNATION	BALL	RACE	BODY
Basic Part No.	52100 Steel Heat Treated MOS ₂ Coated	52100 Steel Heat Treated MOS ₂ Coated	Low Carbon Steel-Cad or Zinc Plated
Basic Part No. & "H"			Alloy Steel Heat Treated Cadmium or Zinc Plated

Notes

1. Add letter "L" to prefix to indicate left hand threads. Example: RML-20.
2. Optional lubricators available. Add "Z" to suffix to indicate zerk type lubricator. Add "F" to suffix to indicate flush type lubricator. Example: RM-20Z, RF-20HF
3. Load ratings do not include effect of lubricators, consult with Radial Engineering Dept. for load ratings with lubricators.
4. Special sizes and materials can be furnished upon request.
5. For PTFE liners add or insert "T" in part number suffix. Example RM-32T or RF-32TH
- *6. M° equals total included misalignment angle for clevis mounted rod end



ROD END BEARINGS- SELF LUBRICATING

MALE SERIES

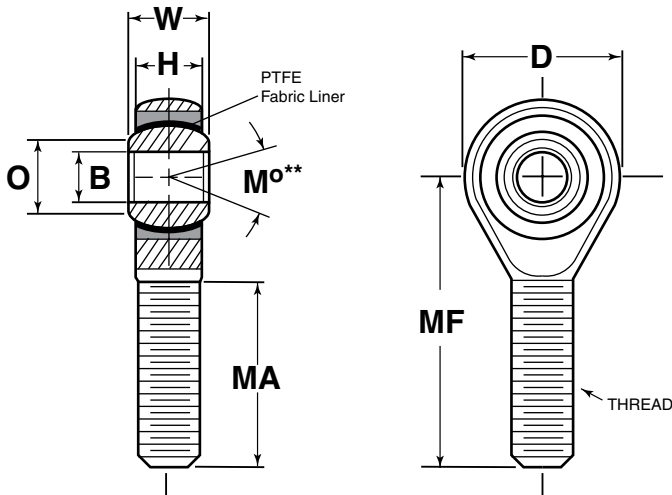

FEMALE SERIES

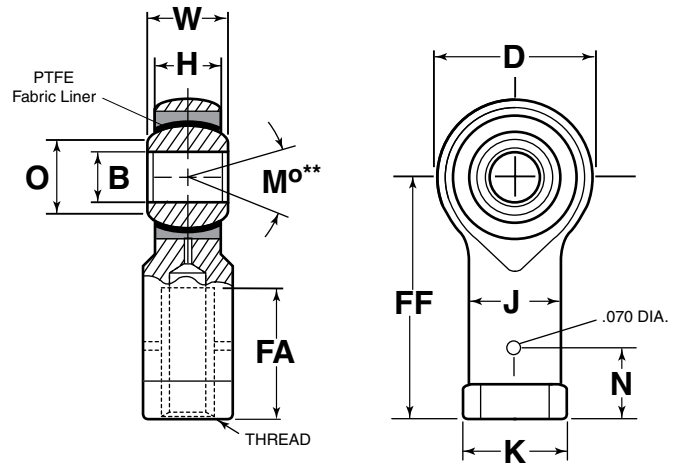

RM-T / RF-T

General Purpose Precision/PTFE Lined

RADIAL PART NO.		B	W	H	O	D	MF	FF	MA	FA	N	K	J	Ball Dia.	Thread	** M°	Max Static Radial Load (LBS)		Approx. Weight (LBS)	
Male	Female	+0015 -0005	+0.000 -0.005	±.005	(REF.)	±.010	±.010	±.010	+1/16 -1/32	+1/16 -1/32	±.020	±.010	±.010	(REF.)	CLASS UNF-3	mis align angle	Male	Female	Male	Female
RM-3T	RF-3T	.1900	.312	.250	.264	.625	1.250	1.062	.750	.562	.312	.406	.312	.406	10-32	13	1,169	1,531	.028	.038
RM-4T	RF-4T	.2500	.375	.281	.331	.750	1.562	1.312	1.000	.750	.312	.468	.375	.500	1/4-28	16	2,158	2,539	.042	.059
RM-5T	RF-5T	.3125	.437	.344	.428	.875	1.875	1.375	1.250	.750	.406	.500	.437	.610	5/16-24	14	2,784	3,133	.072	.092
RM-6T	RF-6T	.3750	.500	.406	.517	1.000	1.938	1.625	1.250	.937	.469	.687	.562	.718	3/8-24	12	3,915	3,915	.112	.152
RM-7T	RF-7T	.4375	.562	.437	.586	1.125	2.125	1.812	1.375	1.062	.531	.750	.625	.812	7/16-20	14	4,218	4,218	.160	.198
RM-8T	RF-8T	.5000	.625	.500	.656	1.312	2.438	2.125	1.500	1.187	.594	.875	.750	.906	1/2-20	12	6,660	6,660	.249	.320
RM-10T	RF-10T	.6250	.750	.562	.821	1.500	2.625	2.500	1.625	1.500	.750	1.000	.875	1.110	5/8-18	16	7,364	7,364	.382	.477
RM-12T	RF-12T	.7500	.875	.687	.937	1.750	2.875	2.875	1.750	1.750	.875	1.125	1.000	1.281	3/4-16	14	11,518	11,518	.602	.723
* RM-16T	RF-16T	1.000	1.375	1.000	1.269	2.750	4.125	4.125	2.125	2.125	-	1.625	1.500	1.875	1 1/4-12	17	43,540	43,540	2.41	2.13
* RM-16T-2	RF-16T-2	1.000	1.375	1.000	1.269	2.750	4.125	4.125	2.125	2.125	-	1.625	1.500	1.875	1-14	17	43,540	43,540	2.13	2.41
* RM-16T-3	RF-16T-3	1.000	1.375	1.000	1.269	2.750	4.125	4.125	2.125	2.125	-	1.625	1.500	1.875	1-12	17	43,540	43,540	2.13	2.41

Materials

BALL	RACE	BODY	LINER
52100 Steel Heat Treated Hard Chrome Plated	Low Carbon Steel Zinc Plated or Stainless Steel	Low Carbon Steel Cadmium or Zinc Plated	PTFE fabric permanently bonded to Race I. D.

Notes

1. Add letter "L" to prefix to indicate left hand threads
Example: RML-6T, RFL-6T
2. Temperature range: -65°F to +250°
3. Special sizes and materials can be furnished upon request. For brass races specify REM/REF.
- *4. Tolerances for -16: "D" +.030, "H" ±.010, "FF" -.010
& "MF" ±.020
- **5. M° equals total included misalignment angle for clevis mounted rod end



MALE SERIES

FEMALE SERIES

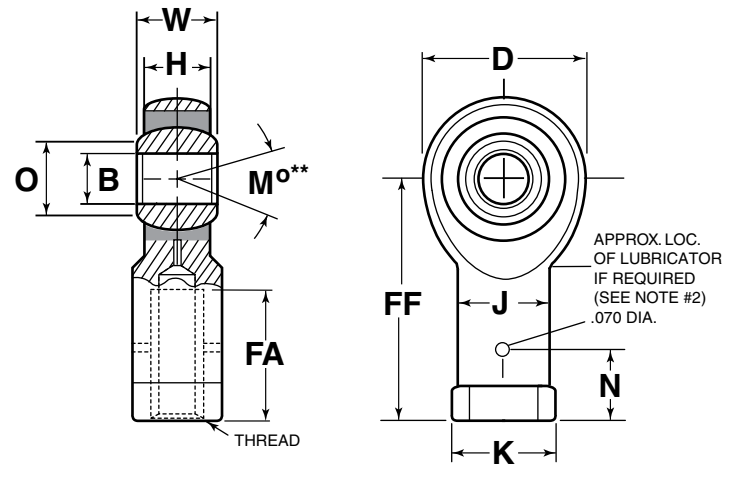
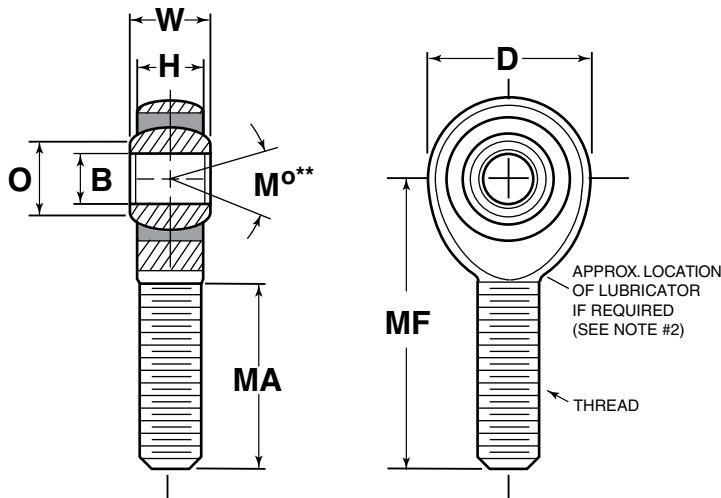

RM-H / RF-H

High Strength Precision

RADIAL PART NO.		B	W	H	O	D	MF	FF	MA	FA	N	K	J	Ball Dia.	Thread	** M° mis align angle	Max Static Radial Load (LBS)		Approx. Weight (LBS)	
Male	Female	+0.0015 -0.0005	+0.000 -0.005	±.005	(REF.)	±.010	±.010	±.010	+1/16 -1/32	+1/16 -1/32	±.020	±.010	±.010	(REF.)	CLASS UNF-3		Male	Female	Male	Female
RM-3H	RF-3H	.1900	.312	.250	.264	.625	1.250	1.062	.750	.562	.312	.406	.312	.406	10-32	13	2,851	3,733	.028	.038
RM-4H	RF-4H	.2500	.375	.281	.331	.750	1.562	1.312	1.000	.750	.312	.468	.375	.500	1/4-28	16	5,260	6,190	.043	.059
RM-5H	RF-5H	.3125	.437	.344	.428	.875	1.875	1.375	1.250	.750	.406	.500	.437	.610	5/16-24	14	7,639	7,639	.072	.092
RM-6H	RF-6H	.3750	.500	.406	.517	1.000	1.938	1.625	1.250	.937	.469	.687	.562	.718	3/8-24	12	9,544	9,544	.112	.152
RM-7H	RF-7H	.4375	.562	.437	.586	1.125	2.125	1.812	1.375	1.062	.531	.750	.625	.812	7/16-20	14	10,285	10,285	.160	.198
RM-8H	RF-8H	.5000	.625	.500	.656	1.312	2.438	2.125	1.500	1.187	.594	.875	.750	.906	1/2-20	12	16,238	16,238	.249	.320
RM-10H	RF-10H	.6250	.750	.562	.821	1.500	2.625	2.500	1.625	1.500	.750	1.000	.875	1.110	5/8-18	16	17,955	17,955	.382	.477
RM-12H	RF-12H	.7500	.875	.687	.937	1.750	2.875	2.875	1.750	1.750	.875	1.125	1.000	1.281	3/4-16	14	28,081	28,081	.602	.723
RM-14H	-	.8750	.875	.687	.978	2.000	3.375	-	1.875	-	-	-	-	1.312	7/8-14	12	55,692	-	.906	-
* RM-16H	RF-16H	1.000	1.375	1.000	1.269	2.750	4.125	4.125	2.125	2.125	-	1.625	1.500	1.875	1 1/4-12	17	76,200	76,200	2.41	2.13
* RM-16H-2	RF-16H-2	1.000	1.375	1.000	1.269	2.750	4.125	4.125	2.125	2.125	-	1.625	1.500	1.875	1-14	17	76,200	76,200	2.13	2.41
* RM-16H-3	RF-16H-3	1.000	1.375	1.000	1.269	2.750	4.125	4.125	2.125	2.125	-	1.625	1.500	1.875	1-12	17	76,200	76,200	2.13	2.41

Materials

BALL	RACE	BODY
52100 Steel Heat Treated Hard Chrome Plated	Steel Alloy Heat Treated Zinc Plated or Stainless Steel Heat Treated	Steel Alloy Heat Treated Cad or Zinc Plated

Notes

- Add letter "L" to prefix to indicate left hand threads.
Example: RML-6H, RFL-6H
- Optional lubricators available on sizes 4-16 only. Add "Z" to suffix to indicate zerk type lubricator. Add "F" to suffix to indicate flush type lubricator.
Example: RM-6HZ, RF-6HZ, RM-6HF, RF-6HF.
- Load ratings do not include effect of lubricators, consult with Radial Engineering Dept. for load ratings with lubricators.
- Special sizes and materials can be furnished upon request. For aluminum-bronze races specify REM/REF.
- Tolerances for -16: "D" +.030, "H" ±.010, "FF" & "MF" ±.020
-.010
- M° equals total included misalignment angle for clevis mounted rod end.



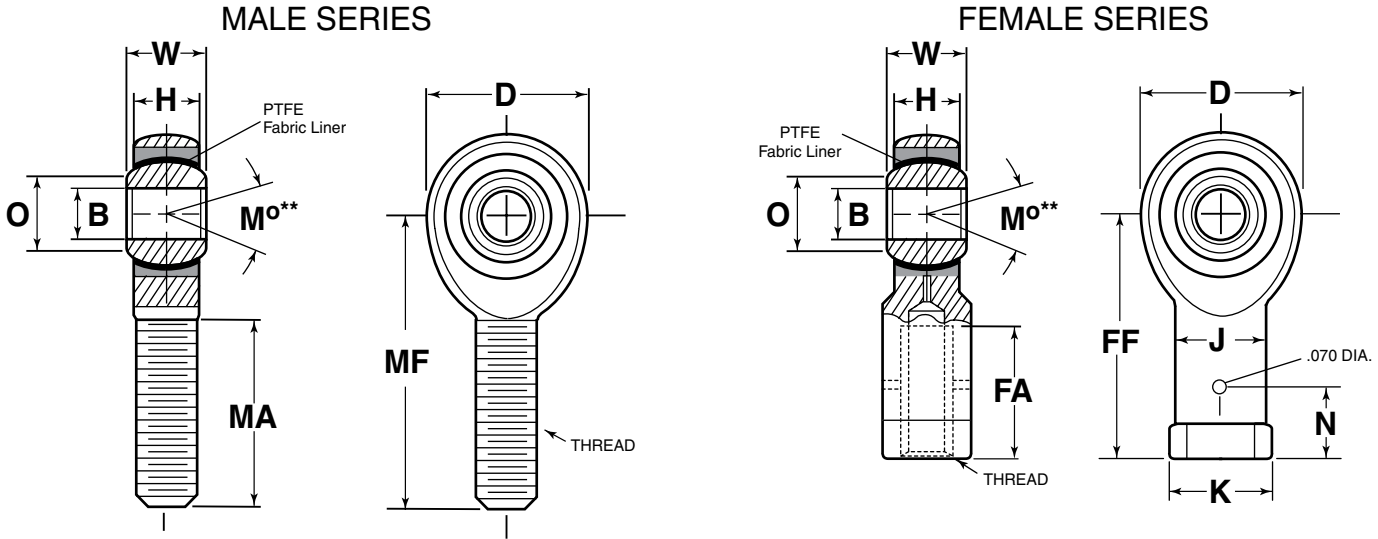

RM-TH / RF-TH

High Strength Precision/ PTFE Lined

RADIAL PART NO.		B	W	H	O	D	MF	FF	MA	FA	N	K	J	Ball Dia.	Thread	** M° mis align angle	Max Static Radial Load (LBS)		Approx. Weight (LBS)	
Male	Female	+0.0015 -.0005	+0.000 -.005	±.005	(REF.)	±.010	±.010	±.010	+1/16 -1/32	+1/16 -1/32	±.020	±.010	±.010	(REF.)	CLASS UNF-3		Male	Female	Male	Female
RM-3TH	RF-3TH	.1900	.312	.250	.264	.625	1.250	1.062	.750	.562	.312	.406	.312	.406	10-32	13	2,851	3,733	.028	.038
RM-4TH	RF-4TH	.2500	.375	.281	.331	.750	1.562	1.312	1.000	.750	.312	.468	.375	.500	1/4-28	16	5,260	6,190	.043	.059
RM-5TH	RF-5TH	.3125	.437	.344	.428	.875	1.875	1.375	1.250	.750	.406	.500	.437	.610	5/16-24	14	7,639	7,639	.072	.092
RM-6TH	RF-6TH	.3750	.500	.406	.517	1.000	1.938	1.625	1.250	.937	.469	.687	.562	.718	3/8-24	12	9,544	9,544	.112	.152
RM-7TH	RF-7TH	.4375	.562	.437	.586	1.125	2.125	1.812	1.375	1.062	.531	.750	.625	.812	7/16-20	14	10,285	10,285	.160	.198
RM-8TH	RF-8TH	.5000	.625	.500	.656	1.312	2.438	2.125	1.500	1.187	.594	.875	.750	.906	1/2-20	12	16,238	16,238	.249	.320
RM-10TH	RF-10TH	.6250	.750	.562	.821	1.500	2.625	2.500	1.625	1.500	.750	1.000	.875	1.110	5/8-18	16	17,955	17,955	.382	.477
RM-12TH	RF-12TH	.7500	.875	.687	.937	1.750	2.875	2.875	1.750	1.750	.875	1.125	1.000	1.281	3/4-16	14	28,081	28,081	.602	.723
RM-14TH	-	.8750	.875	.687	.978	2.00	3.375	-	1.875	-	-	-	-	1.312	7/8-14	12	55,692	-	.906	-
* RM-16TH	RF-16TH	1.000	1.375	1.000	1.269	2.750	4.125	4.125	2.125	2.125	-	1.625	1.500	1.875	1 1/4-12	17	76,200	76,200	2.41	2.13
* RM-16TH-2	RF-16TH-2	1.000	1.375	1.000	1.269	2.750	4.125	4.125	2.125	2.125	-	1.625	1.500	1.875	1-14	17	76,200	76,200	2.13	2.41
* RM-16TH-3	RF-16TH-3	1.000	1.375	1.000	1.269	2.750	4.125	4.125	2.125	2.125	-	1.625	1.500	1.875	1-12	17	76,200	76,200	2.13	2.41

Materials

BALL	RACE	BODY	LINER
52100 Steel Heat Treated Hard Chrome Plated	Steel Alloy Heat Treated Zinc Plated or Stainless Steel Heat Treated	Steel Alloy Heat Treated Cad or Zinc Plated	PTFE fabric permanently bonded to Race I. D.

Notes

1. Add letter "L" to prefix to indicate left hand threads.
Example: RML-6TH, RFL-6TH
2. Temperature range: -65°F to +250°
3. Special sizes and materials can be furnished upon request.
- *4. Tolerances for -16: "D" +.030, "H" ±.010, "FF" -.010 & "MF" ±.020
- **5. M° equals total included misalignment angle for clevis mounted rod end.

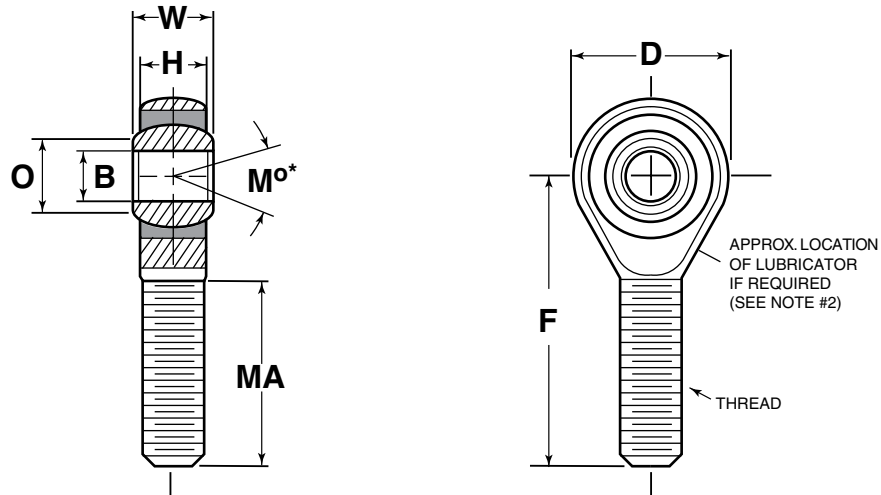

XRM / XRM-H

Mild Steel / Chrome Moly

Heavy Duty Shank

RADIAL PART NO.		B	D	W	H	O	Ball Dia.	F	Thread	MA	* M° misalign angle	Max. Static Radial Load (LBS)		Approx. Weight (LBS)
												XRM	XRM-H	
XRM-3	XRM-3H	.1900 +.0015 -.0005	.750 ± .010	.312 +.000 -.005	.250 ±.005	.264 (REF.)	.406 (REF.)	1.562 ±.015	1/4-28 CLASS UNF-3A	1.000 +.062 -.031	10	2,100	5,200	.043
XRM-4	XRM-4H	.2500	.875	.375	.281	.330	.500	1.875	5/16-24	1.250	13	3,400	8,400	.072
XRM-5	XRM-5H	.3125	1.000	.437	.344	.428	.610	1.938	3/8-24	1.250	12	5,300	12,900	.112
XRM-6	XRM-6H	.3750	1.125	.500	.406	.515	.718	2.125	7/16-20	1.375	10	7,100	17,500	.160
XRM-7	XRM-7H	.4375	1.312	.562	.437	.586	.812	2.438	1/2-20	1.500	12	9,600	23,400	.250
XRM-8	XRM-8H	.5000	1.500	.625	.500	.656	.906	2.625	5/8-18	1.625	10	12,800	31,300	.382
XRM-10	XRM-10H	.6250	1.750	.750	.562	.821	1.110	2.875	3/4-16	1.750	13	16,500	40,500	.602
XRM-12	XRM-12H	.7500	2.000	.875	.687	.937	1.281	3.375	7/8-14	1.875	12	22,800	55,600	.918

Materials

DESIGNATION	BALL	RACE	BODY
Basic Part No.	52100 Steel Heat Treated Hard Chrome Plated	Low Carbon Steel-Cad or Zinc Plated	Low Carbon Steel-Cad or Zinc Plated
Basic Part No. & "H"		Alloy Steel Heat Treated Cadmium or Zinc Plated	Alloy Steel Heat Treated Cadmium or Zinc Plated

Notes

1. Add letter "L" to prefix to indicate left hand threads. Example: XRML-4, XRML-4H.
2. Lubrication fittings available on sizes 4 thru 12. Add "F" to suffix to indicate flush type lubricator. Add "Z" to suffix to indicate zerk type lubricator. Example: XRM-4F, XRM-4HF, XRM-4Z, XRM-4HZ.
3. Load ratings based on no lubrication fitting. For load ratings of male rod ends with lubricator please contact Radial Engineering Dept.
- *4. M° equals total included misalignment angle for clevis mounted rod end.

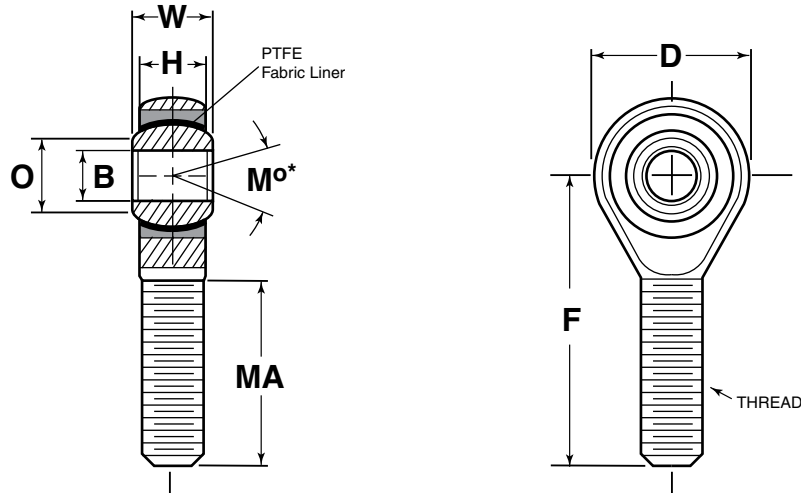

**XRM-T / XRM-TH**

Mild Steel/Chrome Moly

Heavy Duty Shank/ PTFE Lined

RADIAL PART NO.		B	D	W	H	O	Ball Dia.	F	Thread	MA	* M°	Max. Ult. Static Radial Load (LBS)		Approx. Weight (LBS)
		+0.0015 -0.0005	±.010	+0.000 -0.005	±.005	(REF.)	(REF.)	±.015	CLASS UNF-3A	+0.062 -0.031	misalign angle	XRM-T	XRM-TH	
XRM-3T	XRM-3TH	.1900	.750	.312	.250	.264	.406	1.562	1/4-28	1.000	10	2,100	5,200	.043
XRM-4T	XRM-4TH	.2500	.875	.375	.281	.330	.500	1.875	5/16-24	1.250	13	3,400	8,400	.072
XRM-5T	XRM-5TH	.3125	1.000	.437	.344	.428	.610	1.938	3/8-24	1.250	12	5,300	12,900	.112
XRM-6T	XRM-6TH	.3750	1.125	.500	.406	.515	.718	2.125	7/16-20	1.375	10	7,100	17,500	.160
XRM-7T	XRM-7TH	.4375	1.312	.562	.437	.586	.812	2.438	1/2-20	1.500	12	9,600	23,400	.250
XRM-8T	XRM-8TH	.5000	1.500	.625	.500	.656	.906	2.625	5/8-18	1.625	10	12,800	31,300	.382
XRM-10T	XRM-10TH	.6250	1.750	.750	.562	.821	1.110	2.875	3/4-16	1.750	13	16,500	40,500	.602
XRM-12T	XRM-12TH	.7500	2.000	.875	.687	.937	1.281	3.375	7/8-14	1.875	12	22,800	55,600	.918

Materials

DESIGNATION	BALL	RACE	BODY	LINER
Basic Part No.	52100 Steel Heat Treated	Stainless Steel Heat Treated	Low Carbon Steel-Cad or Zinc Plated	PTFE Fabric Permanently Bonded to Race I. D.
Basic Part No. & "H"	Hard Chrome Plated		Alloy Steel Heat Treated Cadmium or Zinc Plated	

Notes

- Add letter "L" to prefix to indicate left hand threads. Example: XRML-6T, XRML-6TH.
- Temperature range: -65°F to +250°
- Special sizes and materials can be furnished upon request.
- M° equals total included misalignment angle for clevis mounted rod end.

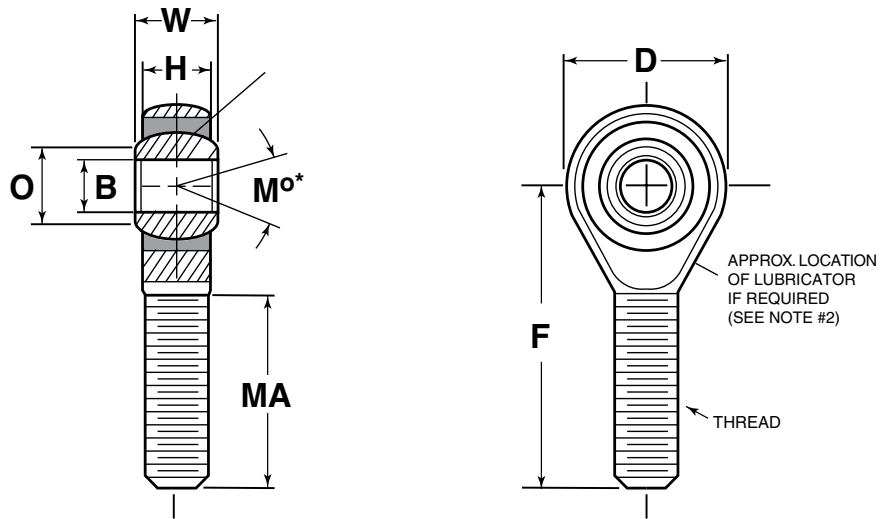

REMX

Extra Capacity Series

RADIAL PART NO.	B	D	W	H	O	Ball Dia.	F	Thread	MA	* M°	Max. Static Radial Load (LBS)		Approx. Weight (LBS)
	+0.0015 -0.0005	±.010	+0.000 -0.005	±.005	(REF.)	(REF.)	±.010	CLASS UNF-3A	+1/16 -1/32	misalign angle	RADIAL	AXIAL	
REMX - 4	.2500	.750	.375	.281	.331	.500	1.562	5/16-24	1.000	16	5,390	1,700	.06
REMX - 5	.3125	.875	.437	.344	.428	.610	1.875	3/8-24	1.250	14	7,500	2,375	.09
REMX - 6	.3750	1.000	.500	.406	.517	.718	1.938	7/16-20	1.250	12	9,590	2,950	.13
REMX - 7	.4375	1.125	.562	.437	.586	.812	2.125	1/2-20	1.375	14	11,000	3,350	.18
REMX - 8	.5000	1.312	.625	.500	.656	.906	2.438	5/8-18	1.500	12	13,575	4,075	.30
REMX -10	.6250	1.500	.750	.562	.821	1.110	2.625	3/4-16	1.625	16	17,300	5,150	.46
REMX - 12	.7500	1.750	.875	.687	.937	1.281	2.875	7/8-14	1.750	14	23,225	6,750	.72

Materials

Notes

PART #	BODY	BALL	RACE
As Shown	Alloy Steel Heat Treated	52100 Steel Heat Treated	Alum. Bronze
REMX-SS	Mag. Inspected Cad. or Zinc Plated	Hard Chrome Plated	Stainless Steel

1. Add letter "L" to prefix to indicate left hand threads. Example: REMXL-5SS
2. Optional lubricators available. Add "Z" to suffix to indicate zerk type lubricator. Add "F" to suffix to indicate flush type lubricator. Example: REMX-6Z, REMX-7F.
3. Load ratings do not include effect of lubricators, consult with Radial Engineering Dept. for load ratings with lubricators.
4. Special sizes and materials can be furnished upon request.
- *5. M° equals total included misalignment angle for clevis mounted rod end.

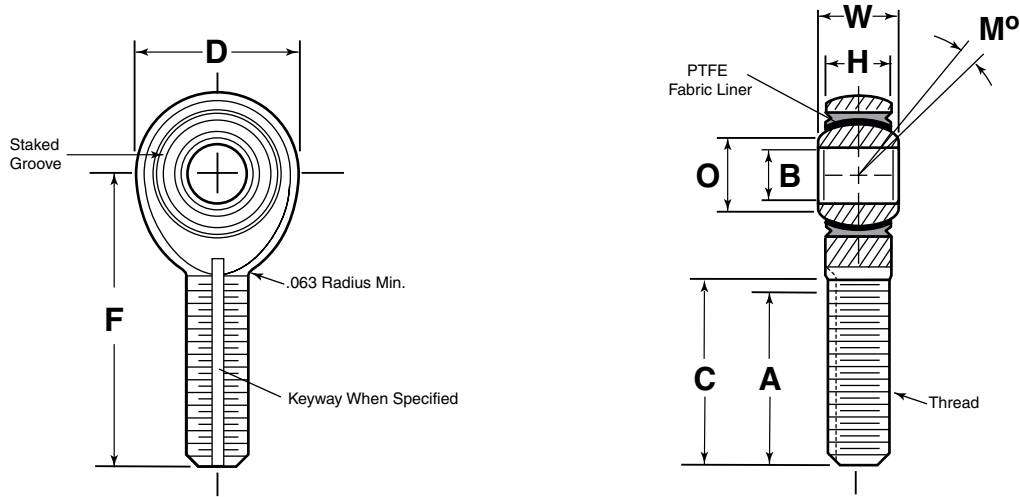

Male Aerospace Series PTFE Lined/High Strength

REM-TH-5 / REM-TH-6

RADIAL PART NO.	B	D	W	H	O	Ball Dia.	F	Thread	A	C	Ult. Static Radial Load (LBS)	Fatigue Load (LBS)	Axial Proof Load (LBS)	No Load Break-away Torque (Inch LBS)	M° mis-align angle	Approx Weight (LBS)
	+0.0000 -0.0005	±.010	+0.000 -0.002	±.005	(MIN.)	(REF.)	±.010	CLASS UNJF-3A	±.031	+0.000 -0.020						
REM-3TH	.1900	.806	.437	.337	.300	.531	1.562	.3125-24	.968	.980	2,360	1,470	1,000	.5 to 6	15	.072
REM-4TH	.2500	.806	.437	.337	.300	.531	1.562	.3125-24	.968	.980	4,860	2,380	1,000	.5 to 6	15	.072
REM-5TH	.3125	.900	.437	.327	.360	.593	1.875	.3125-24	1.187	1.270	7,180	2,770	1,100	1 to 15	14	.087
REM-6TH	.3750	1.025	.500	.416	.470	.687	1.938	.3750-24	1.187	1.235	8,550	3,670	1,660	1 to 15	8	.136
REM-7TH	.4375	1.150	.562	.452	.540	.781	2.125	.4375-20	1.281	1.402	12,000	4,800	1,850	1 to 15	10	.183
REM-8TH	.5000	1.337	.625	.515	.610	.875	2.438	.5000-20	1.468	1.589	19,500	7,680	2,040	1 to 15	9	.278
REM-10TH	.6250	1.525	.750	.577	.750	1.062	2.625	.6250-18	1.562	1.683	21,900	9,180	2,430	1 to 15	12	.424
REM-12TH	.7500	1.775	.875	.640	.850	1.250	2.875	.7500-16	1.687	1.808	29,300	11,600	2,810	1 to 15	13	.639
REM-14TH	.8750	2.025	.875	.765	1.000	1.375	3.375	.8750-14	2.000	2.121	34,500	13,100	3,320	1 to 24	6	.963
REM-16TH	1.000	2.775	1.375	1.015	1.270	1.875	4.125	1.2500-12	2.343	2.464	80,300	30,400	4,340	1 to 24	12	2.546

Materials

DESIGNATION	BALL	RACE	LINER	BODY
Basic Part No. +5	440C CRES Heat Treated	17-4 PH AMS-5643 CRES Heat Treated	PTFE fabric permanently bonded to Race I. D.	4340 Steel Heat Treated See Note #4
Basic Part No. +6	Hard Chrome Plated			17-4 PH CRES Heat Treated

Notes

1. Add letter "L" to prefix to indicate left hand threads. Example: REML-3TH-6.
2. For keyway per NAS 559 add suffix "K" to part number. Example: REM-3TH-6K.
3. Bearings listed on this page conform to materials, dimensions, and configurations of Mil-B-81935; however, Radial is not approved for procurement under that specification. Consult factory for additional information.
4. Protective plating in accordance with latest revision of Mil-B-81935.



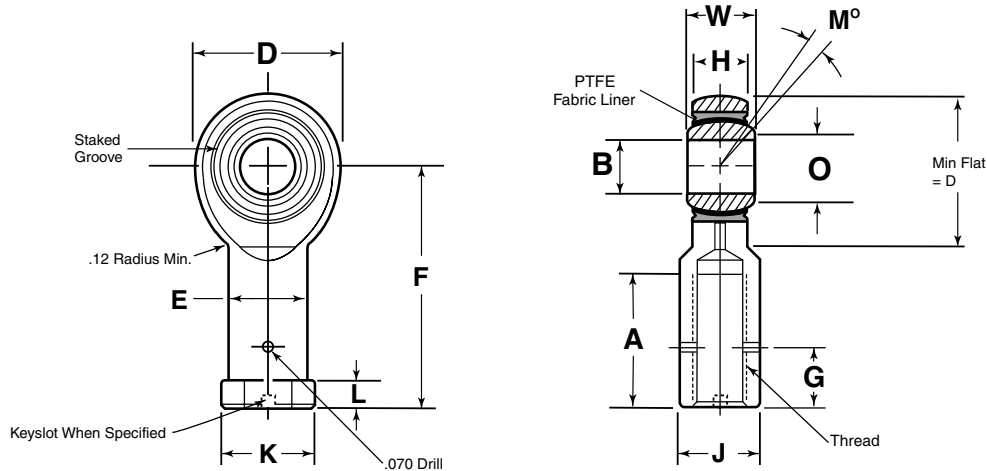

REF-TH-5 / REF-TH-6

Female/Aerospace Series PTFE Lined/High Strength

RADIAL PART NO.	B	D	W	H	O	Ball Dia.	F	Thread	A	G	E	K	L	J	Ult. Static Radial Load (LBS)	Fatigue Load (LBS)	Axial Proof (LBS)	No Load Break-away Torque (Inch LBS)	M° mis-align angle	Approx Weight (LBS)
	+0.0000 -0.0005	±.010	+0.000 -0.002	±.005	(MIN.)	(REF.)	±.010	CLASS UNJF-3B	MIN	±.020	±.010	REF DIA.	+0.010 -0.062	+0.002 -0.010						
REF-3TH	.1900	.806	.437	.337	.300	.531	1.375	.3125-24	.750	.375	.422	.500	.188	.437	2,360	1,470	1,000	.5 to 6	15	.080
REF-4TH	.2500	.806	.437	.337	.300	.531	1.469	.3125-24	.750	.375	.422	.500	.188	.437	4,860	2,380	1,000	.5 to 6	15	.084
REF-5TH	.3125	.900	.437	.327	.360	.593	1.625	.3750-24	.875	.437	.485	.580	.250	.500	7,180	2,770	1,100	1 to 15	14	.102
REF-6TH	.3750	1.025	.500	.416	.470	.687	1.812	.3750-24	1.000	.437	.547	.660	.250	.562	8,550	3,670	1,660	1 to 15	8	.161
REF-7TH	.4375	1.150	.562	.452	.540	.781	2.000	.4375-20	1.125	.500	.610	.720	.250	.625	12,000	4,800	1,850	1 to 15	10	.212
REF-8TH	.5000	1.337	.625	.515	.610	.875	2.250	.5000-20	1.250	.562	.735	.880	.250	.750	19,500	7,680	2,040	1 to 15	9	.325
REF-10TH	.6250	1.525	.750	.577	.750	1.062	2.500	.6250-18	1.375	.687	.860	1.020	.375	.875	21,900	9,180	2,430	1 to 15	12	.481
REF-12TH	.7500	1.775	.875	.640	.850	1.250	2.875	.7500-16	1.625	.812	.985	1.160	.375	1.000	29,300	11,600	2,810	1 to 15	13	.673
REF-14TH	.8750	2.025	.875	.765	1.000	1.375	3.375	.8750-14	1.875	.937	1.110	1.300	.500	1.125	34,500	13,100	3,320	1 to 24	6	.959
REF-16TH	1.000	2.775	1.375	1.015	1.270	1.875	4.125	1.2500-12	2.125	1.312	1.688	2.020	.563	1.750	80,300	30,400	4,340	1 to 24	12	2.717

Materials

DESIGNATION	BALL	RACE	LINER	BODY
Basic Part No. +5	440C CRES Heat Treated	17-4 PH AMS-5643 CRES Heat Treated	PTFE fabric permanently bonded to Race I. D.	4340 Steel Heat Treated See Note #4
Basic Part No. +6	Hard Chrome Plated			17-4 PH CRES Heat Treated

Notes

1. Add letter "L" to prefix to indicate left hand threads. Example: REFL-3TH-6.
2. For keyway per NAS 559 add suffix "K" to part number. Example: REF-3TH-6K.
3. Bearings listed on this page conform to materials, dimensions, and configurations of Mil-B-81935; however, Radial is not approved for procurement under that specification. Consult factory for additional information.
4. Protective plating in accordance with latest revision of Mil-B-81935.



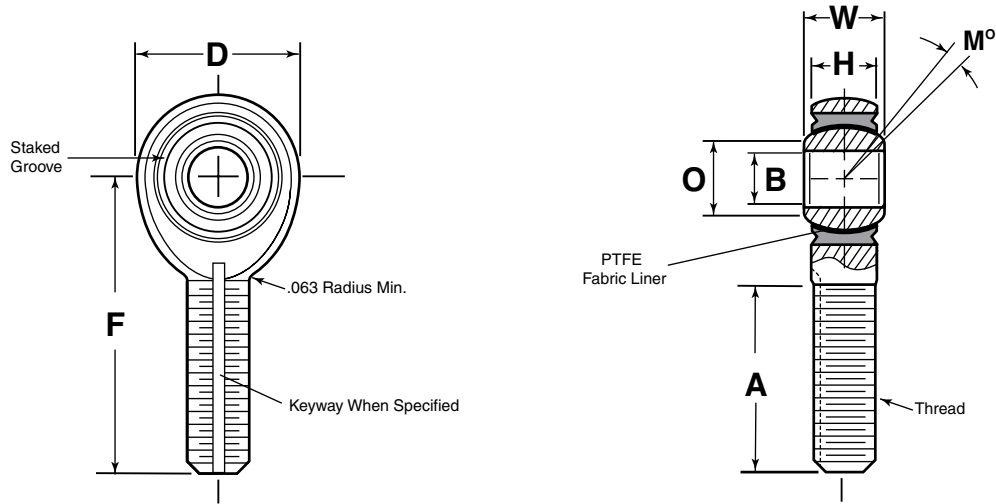

Male/Heavy Duty Shank
High Performance/ PTFE Lined

XRM-TH-5 / XRM-TH-6

RADIAL PART NO.	B	D	W	H	O	Ball Dia.	F	Thread	A	Ult. Static Radial Load (LBS)	No Load Break-away Torque (Inch LBS)	Axial Proof Load (LBS)	M° mis-align angle	Approx Weight (LBS)
	+0000 -.0005	±.010	+000 -.002	±.005	(REF.)	(REF.)	±.010	CLASS UNF-3A	±.031					
XRM-4TH	.2500	.806	.375	.337	.375	.531	1.562	5/16-24	.968	7,550	.5 to 6	1,000	5	.067
XRM-5TH	.3125	.900	.437	.327	.401	.593	1.875	3/8-24	1.187	9,200	1 to 10	1,100	14	.095
XRM-6TH	.3750	1.025	.500	.416	.471	.687	1.938	7/16-20	1.187	10,900	1 to 10	1,660	9	.140
XRM-7TH	.4375	1.150	.562	.452	.542	.781	2.125	1/2-20	1.281	14,050	1 to 10	1,850	10	.210
XRM-8TH	.5000	1.337	.625	.515	.612	.875	2.438	5/8-18	1.468	23,100	1 to 10	2,040	9	.330
XRM-10TH	.6250	1.525	.750	.577	.752	1.062	2.625	3/4-16	1.562	26,050	1 to 10	2,430	12	.480
XRM-12TH	.7500	1.775	.875	.640	.892	1.250	2.875	7/8-14	1.687	34,500	1 to 10	2,810	13	.730

Materials

DESIGNATION	BALL	RACE	BODY	LINER
Basic Part No. +5	440C CRES Heat Treated	17-4 PH AMS-5643 Heat Treated	C. M. Steel Heat Treated Cadmium or Zinc Plated	PTFE fabric Permanently Bonded to Race I. D.
Basic Part No. +6			17-4 PH CRES Heat Treated	

Notes

1. Add letter "L" to prefix to indicate left hand threads. Example: XRML-4TH-6.
2. For keyway per NAS 559 add suffix "K" to part number. Example: XRM-4TH-6K.

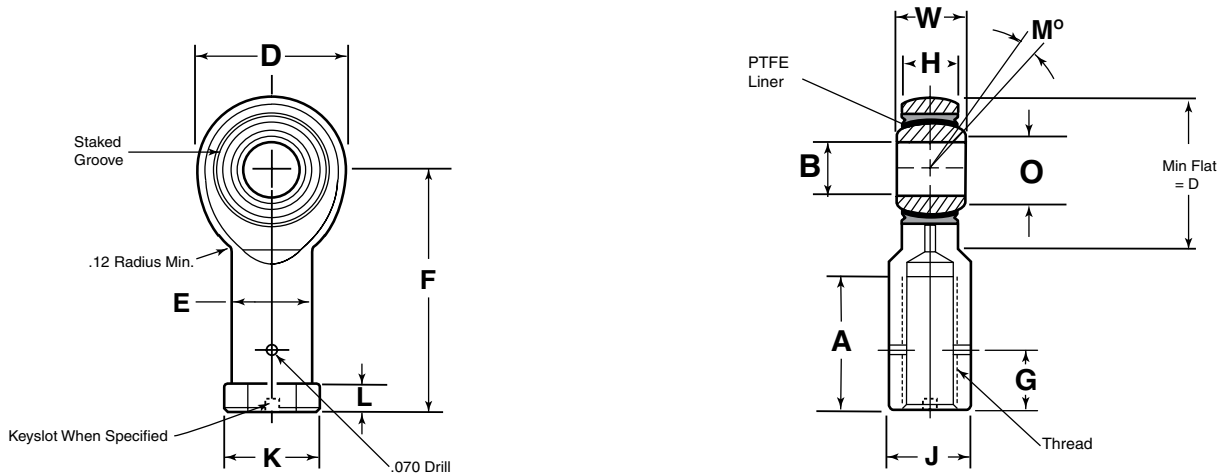

Female/Heavy Duty Shank High Performance/ PTFE Lined

XRF-TH-5 / XRF-TH-6

RADIAL PART NO.	B	D	W	H	O	Ball Dia.	F	Thread	A	G	E	K	L	J	Ult. Static Radial Load (LBS)	Axial Proof Load (LBS)	No Load Break-away Torque (Inch LBS)	M° mis-align angle	Approx. Weight (LBS)
	+0.0000 -0.0005	±.010	+0.000 -0.002	±.005	(REF.)	(REF.)	±.010	CLASS UNF-3B	MIN	±.020	±.010	DIA.	+0.010 -0.062	+0.002 -0.010					
XRF-4TH	.2500	.806	.375	.337	.375	.531	1.469	5/16-24	.750	.375	.485	.562	.188	.500	7,550	1,000	.5 to 6	5	.084
XRF-5TH	.3125	.900	.437	.327	.401	.593	1.625	3/8-24	.875	.437	.547	.625	.250	.562	9,200	1,100	1 to 10	14	.102
XRF-6TH	.3750	1.025	.500	.416	.471	.687	1.812	7/16-20	1.000	.500	.610	.687	.250	.625	10,900	1,660	1 to 10	9	.160
XRF-7TH	.4375	1.150	.562	.452	.542	.781	2.000	1/2-20	1.125	.562	.735	.875	.250	.750	14,050	1,850	1 to 10	10	.230
XRF-8TH	.5000	1.337	.626	.515	.612	.875	2.250	5/8-18	1.250	.687	.860	1.000	.250	.875	23,100	2,040	1 to 10	9	.340
XRF-10TH	.6250	1.525	.750	.577	.752	1.062	2.500	3/4-16	1.375	.812	.985	1.125	.375	1.000	26,050	2,430	1 to 10	12	.490
XRF-12TH	.7500	1.775	.875	.640	.892	1.250	2.875	7/8-14	1.625	.937	1.110	1.250	.375	1.125	34,500	2,810	1 to 10	13	.740

Materials

DESIGNATION	BALL	RACE	LINER	BODY
Basic Part No. +5	440C CRES	17-4 PH AMS-5643	PTFE fabric Permanently Bonded to Race I. D.	C. M. Steel Heat Treated Cad or Zinc Plated
Basic Part No. +6	Heat Treated	Heat Treated		17-4 PH CRES Heat Treated

Notes

1. Add letter "L" to prefix to indicate left hand threads. Example: XRFL-4TH-6.
2. For keyway per NAS 559 add suffix "K" to part number. Example: XRF-4TH-6K.

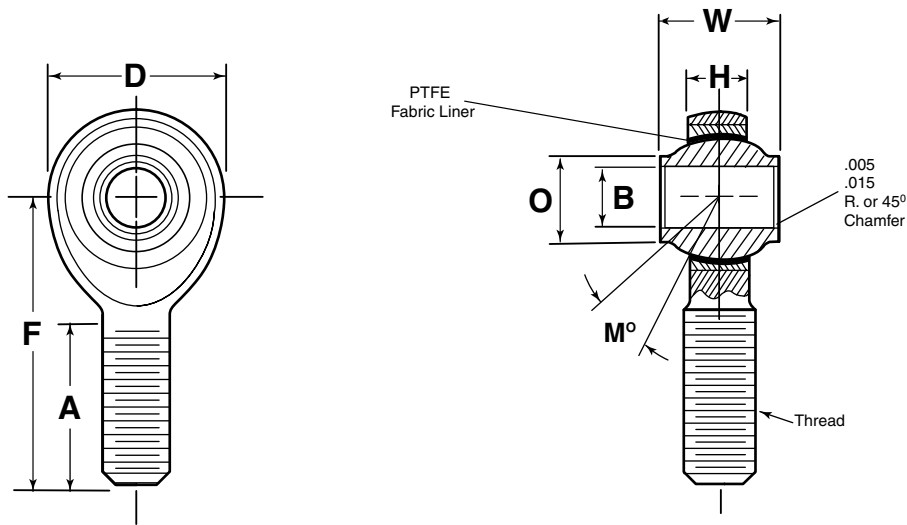

High Misalignment PTFE Lined

RMYT-H

RADIAL PART NO.	B	D	W	H	O	Ball Dia.	F	Thread	A	Ult. Static Radial Load (LBS)	No Load Break-away Torque (Inch LBS)	M° misalign angle	Approx Weight (LBS)
	+0.0000 -0.0005	±.010	+0.000 -0.005	±.005	(REF.)	(REF.)	±.010	CLASS UNF-3A	+0.062 -0.031				
RMYT-3H	.1900	.750	.500	.220	.319	.437	1.500	5/16-24	1.000	4,830	.5 to 6	13	.07
RMYT-4H	.2500	1.000	.593	.265	.390	.593	1.938	3/8-24	1.250	8,650	1 to 15	23	.11
RMYT-5H	.3125	1.125	.813	.355	.512	.781	2.125	7/16-20	1.375	9,050	1 to 15	22	.16
RMYT-6H	.3750	1.125	.813	.355	.512	.781	2.125	7/16-20	1.375	9,050	1 to 15	22	.15
RMYT-7H	.4375	1.312	.875	.355	.618	.875	2.438	1/2-20	1.500	14,100	1 to 15	21	.25
RMYT-8H	.5000	1.500	.937	.411	.730	1.000	2.625	5/8-18	1.625	19,800	1 to 15	19	.39
RMYT-10H	.6250	1.750	1.200	.577	.856	1.250	2.875	3/4-16	1.750	26,500	1 to 15	19	.62
RMYT-12H	.7500	2.000	1.280	.630	.970	1.375	3.375	7/8-14	1.875	34,200	1 to 15	18	.90
RMYT-14H	.8750	2.200	1.400	.635	1.140	1.531	3.750	7/8-14	2.000	36,400	1 to 15	17	1.08
RMYT-16H	1.000	2.750	1.875	.845	1.278	1.875	4.125	1 1/4-12	2.125	66,500	2 to 24	20	2.20
RMYT-20H	1.250	3.125	1.875	1.045	1.523	2.250	5.000	1 1/4-12	2.875	80,000	2 to 24	20	3.10

Materials

DESIGNATION	BALL	RACE	BODY	LINER
Basic Part No.	440C CRES Heat Treated	Stainless Steel Heat Treated	C. M. Steel Heat Treated Cadmium Plated	PTFE fabric Permanently Bonded to Race I. D.
Basic Part No. +SS			17-4 PH CRES Heat Treated	

Notes

1. Add letter "L" to prefix to indicate left hand threads. Example: RMYTL-4H.
2. For keyway per NAS 559 add suffix "K" to part number. Example: RMYT-8HK.
3. Temperature range: -65°F to +325°F.



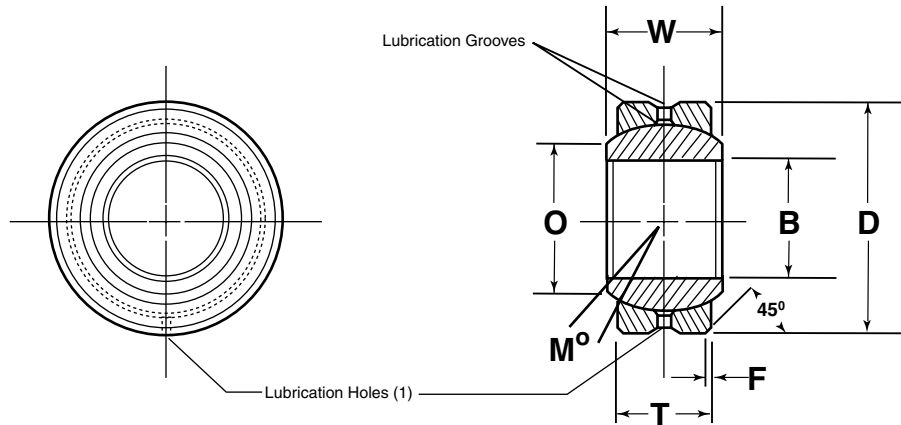

CRS Commerical

PTFE Liner Available

RADIAL PART NO.	B	O	D	F	T	W	Ball Dia.	M°	HOUSING BORE	MAX. Static Radial Load (LBS)	Approx Weight (LBS)
	+0.0015 -0.0005	(REF.)	+0.0000 -0.0007	(REF.)	±.005	±.005	(REF.)	misalign angle	Recommended Alum. or Steel		
CRS-3	.1900	.293	.5625	.020	.218	.281	.406	11	.5623 .5618	3,250	.014
CRS-4	.2500	.364	.6562	.022	.250	.343	.500	13.5	.6560 .6555	4,900	.022
CRS-5	.3125	.419	.7500	.032	.281	.375	.562	12	.7498 .7493	6,450	.030
CRS-6	.3750	.517	.8125	.032	.312	.406	.656	10	.8123 .8118	8,250	.038
CRS-7	.4375	.572	.9062	.032	.343	.437	.718	8	.9060 .9055	10,200	.048
CRS-8	.5000	.642	1.000	.032	.390	.500	.813	9.5	.9998 .9993	13,600	.065
CRS-9	.5625	.670	1.0937	.032	.437	.562	.906	9.5	1.0935 1.0930	15,900	.086
CRS-10	.6250	.739	1.1875	.032	.500	.625	.968	8.5	1.1873 1.1868	21,000	.110
CRS-12	.7500	.920	1.4375	.044	.593	.750	1.187	9	1.4373 1.4368	30,000	.204
CRS-14	.8750	.980	1.5625	.044	.703	.875	1.312	9.5	1.5623 1.5618	41,100	.263
CRS-16	1.0000	1.118	1.7500	.044	.797	1.000	1.500	10	1.7498 1.7493	54,700	.386

Materials

BALL	RACE
52100 Steel Heat Treated & Chrome Plated	Low Carbon Steel Oil Coated

Notes

1. Basic radial static load is determined from 0.20% permanent set based on the nominal ball diameter per ARTC recommendation.
2. Basic axial yield allowable load is 20% of basic radial yield allowable load.
3. Standard radial clearance between ball and outer race .003 max. Special clearance can be furnished upon request.
4. PTFE Liner available upon request. Add suffix "T", Example: CRS-6T



Wide Standard Series

RW / RW-V

PTFE Liner Available

RADIAL PART NO.		B	D	W	H	Ball Dia.	M ^o misalign angle	O	F	Recomm'd Housing Bore Dia.	Alum. Bronze Static Rad. Lim. Load	Stainless Static Rad. Lim. Load	Approx. Weight (LBS)
Plain	Grooved	+0.000 -0.005	+0.000 -0.005	+0.000 -0.005	+0.010 -0.000	(REF.)	±	(REF.)	+0.015 -0.000	+0.000 -0.005	(LBS)	(LBS)	(LBS)
-3	-3V	.1900	.5000	.359	.281	.437	15 ^o	.249	.010	.5000	3,300	8,700	.015
-3-1	-3-1V	.1900	.6250	.437	.322	.531	18 ^o	.301	.010	.6250	4,700	12,350	.026
-4	-4V	.2500	.6250	.437	.322	.531	18 ^o	.301	.010	.6250	4,700	12,350	.028
-5	-5V	.3125	.6875	.437	.312	.593	15 ^o	.401	.010	.6875	5,150	13,500	.029
-6	-6V	.3750	.8125	.500	.401	.687	10 ^o	.471	.010	.8125	7,750	20,300	.049
-7	-7V	.4375	.9375	.562	.437	.781	11 ^o	.542	.010	.9375	9,750	25,450	.072
-8	-8V	.5000	1.0000	.625	.500	.875	10 ^o	.612	.020	1.0000	12,500	32,800	.089
-9	-9V	.5625	1.1250	.687	.531	1.000	11 ^o	.726	.020	1.1250	15,350	40,250	.123
-10	-10V	.6250	1.1875	.750	.562	1.062	12 ^o	.752	.020	1.1875	17,300	45,400	.140
-12	-12V	.7500	1.3750	.875	.625	1.250	14 ^o	.892	.020	1.3750	22,900	60,000	.208
-14	-14V	.8750	1.6250	.875	.750	1.375	6 ^o	1.061	.020	1.6250	30,150	79,200	.325
-15	-15V	.9375	1.3750	.450	.350	1.188	5 ^o	1.099	.010	1.3750	12,000	31,550	.087
-16	-16V	1.0000	2.1250	1.375	1.000	1.875	14 ^o	1.275	.020	2.1250	55,500	145,650	.870
-20	-20V	1.2500	2.3750	1.500	1.125	2.093	13 ^o	1.464	.020	2.3750	69,900	183,350	1.107
-20-1	-20V-1	1.2500	2.0000	1.093	.937	1.781	6 ^o	1.408	.020	2.0000	49,350	129,600	.526
-22	-22V	1.3750	2.5625	1.687	1.218	2.281	15 ^o	1.539	.020	2.5625	82,600	216,850	1.385
-24	-24V	1.5000	2.6875	1.687	1.218	2.390	14 ^o	1.697	.030	2.6875	86,950	228,300	1.480
-28	-28V	1.7492 1.7500	2.9990 3.0000	1.812	1.312	2.672	13 ^o	1.966	.030	2.9992 3.0000	105,250	276,300	1.905
-32	-32V	1.9992 2.0000	3.2490 3.2500	1.937	1.375	2.937	13 ^o	2.211	.030	3.2492 3.2500	121,850	319,800	2.230
-36	-36V	2.2492 2.2500	3.6240 3.6250	2.000	1.406	3.156	12 ^o	2.444	.030	3.6242 3.6250	134,450	352,850	2.775
-40	-40V	2.4990 2.5000	3.9362 3.9375	2.062	1.437	3.437	12 ^o	2.752	.030	3.9365 3.9375	150,300	394,550	3.288
-44	-44V	2.7490 2.7500	4.1237 4.1250	2.187	1.500	3.687	12 ^o	2.971	.030	4.1240 4.1250	168,700	442,900	3.536
-48	-48V	2.9990 3.0000	4.3737 4.3750	2.312	1.562	3.937	12 ^o	3.190	.030	4.3740 4.3750	188,000	493,550	3.957



Wide Standard Series Cont.

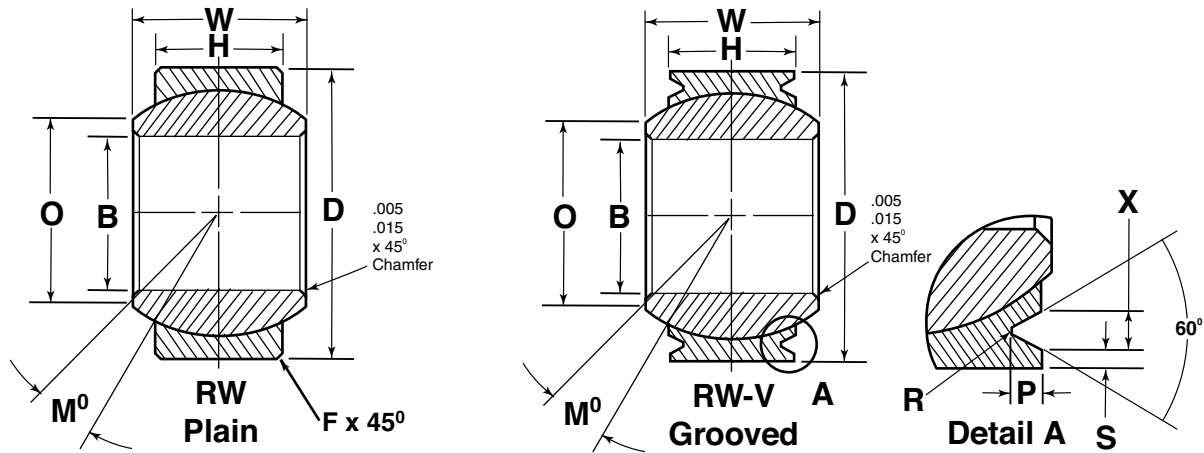

STAKING GROOVE DATA

BORE SIZES	S	X	R	P
	+0.000 -0.010	+0.000 -0.010	+0.000 -0.010	+0.000 -0.015
	LAND MIN.	GROOVE	RADIUS	DEPTH
(3) THRU (5)	.020	.045	.015	.030
(6) THRU (10)	.030	.055	.020	.040
(12) THRU (48)	.030	.080	.020	.060

Materials

DESIGNATION	BALL	RACE
RWB	52100 Steel H. T. & Chrome Plated	* Aluminum Bronze
RWS	52100 Steel H. T. & Chrome Plated	4130 Steel Heat Treated & Cadimum Plated
RWSS	52100 Steel H. T. & Chrome Plated	17-4PH Stainless Steel, Heat Treated
RWCR	440C Stainless Steel H.T. & Chrome Plated	17-4PH Stainless Steel, Heat Treated

Notes

- Standard radial clearance between ball and outer race .002 max. Special clearance can be furnished upon request.
- Diameters "B" and "D" are concentric within .005 T. I. R.
- Dimensions are met AFTER plating.
- *If Cadimum plating is required, add suffix "C".
- Add "A" to suffix if I. D. lube groove in ball & 3 lube holes through ball are required. Example; RWB-3A.
- Add "G" to suffix if O. D. lube groove in race & 3 lube holes through race are required.
- Load ratings are for parts as shown. Consult with Radial Engineering Dept. for effect of lubication grooves in race or PTFE liners.
- PTFE liners are available. Add suffix "T" Ex. RWCR-8T.

SPHERICAL BEARINGS/METAL TO METAL

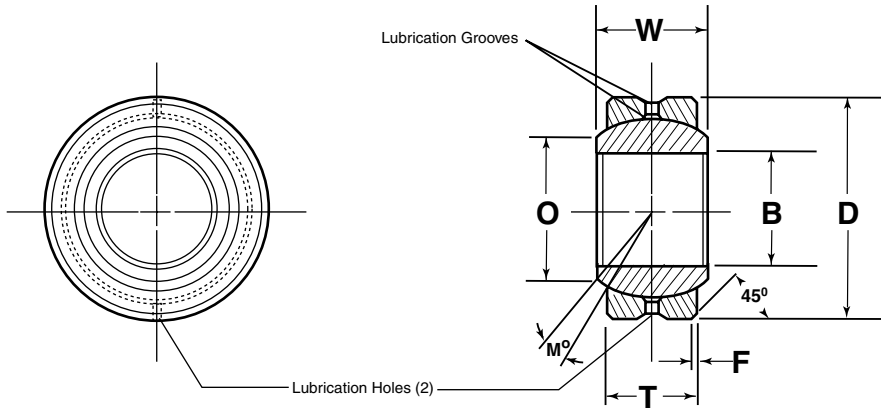

Precision
Metal to Metal Series
PTFE Liner Available

R / RB / RS / RSS / RCR / R-SS

RADIAL PART NO.	B +.0000 -.0005	O (REF.)	D +.0000 -.0005	F +.000 -.010	T ±.005	W +.000 -.005	Ball Dia. (REF.)	M° misalign angle	HOUSING BORE Recommended Alum. or Steel	MAX. Static Radial Load (LBS)		Approx Weight (LBS)
										BRONZE RACE	ALLOY STEEL RACE	
-3	.1900	.293	.5625	.020	.218	.281	.406	11	.5623 .5618	2,700	5,400	.014
-4	.2500	.364	.6562	.022	.250	.343	.500	13	.6560 .6555	4,200	8,400	.022
-5	.3125	.419	.7500	.032	.281	.375	.562	12	.7498 .7493	5,800	11,600	.030
-6	.3750	.517	.8125	.032	.312	.406	.656	10	.8123 .8118	7,800	15,600	.038
-7	.4375	.572	.9062	.032	.343	.437	.718	9	.9060 .9055	9,300	18,600	.048
-8	.5000	.642	1.000	.032	.390	.500	.813	9	.9998 .9993	11,200	22,400	.065
-9	.5625	.672	1.0937	.031	.437	.562	.875	9	1.0935 1.0930	15,000	30,000	.086
-10	.6250	.739	1.1875	.032	.500	.625	.968	9	1.1873 1.1868	20,000	40,000	.110
-12	.7500	.920	1.4375	.044	.593	.750	1.187	9	1.4373 1.4368	30,000	78,000	.204
-14	.8750	.980	1.5625	.044	.703	.875	1.312	9	1.5623 1.5618	43,000	86,000	.263
-16	1.0000	1.118	1.7500	.044	.797	1.000	1.500	10	1.7498 1.7493	52,000	104,000	.386

Materials

PART #	BALL	RACE
R	52100 Steel H. T. & Chrome Plated	Alum. Bronze
RB	52100 Steel H. T. & Chrome Plated	Alum. Bronze Cad. Plated
RS	52100 Steel H. T. & Chrome Plated	4130 Steel or Equal H. T. Cad. Plated
RSS	52100 Steel H. T. & Chrome Plated	17-4 PH or Equal Stainless Steel Heat Treated
RCR	440C Stainless Steel H. T. & Chrome Plated	303 SS or Equal
R-SS	Type 440C Stainless Steel H. T. & Chrome Plated	303 SS or Equal

Notes

- Basic radial allowable load is determined from 0.20% permanent set based on the nominal ball diameter per ARTC recommendation.
- Basic axial yield allowable load is 20% of basic radial yield allowable load.
- Standard radial clearance between ball and outer race .002 max. For .001 radial clearance add "X" to P/N suffix, for .0005 add "XX". Example RS-10X, RCR-10XX
- Dim "B" and "D" are concentric within .005 total indicator reading.
- Add "A" after material code designation if groove in I. D. and oil holes are required in ball. Example: RB-10A
- All Dimensions and tolerances are met after plating. For RS series cadmium plating on all surfaces exposed after installation. For cad. plate on O. D. add "C" to the suffix. Example: RS-10AC.
- Load ratings are for parts as shown. Consult with Radial Engineering Dept. for ratings on lined parts.
- PTFE Liner available. Add suffix "T". Example: RS-8T.



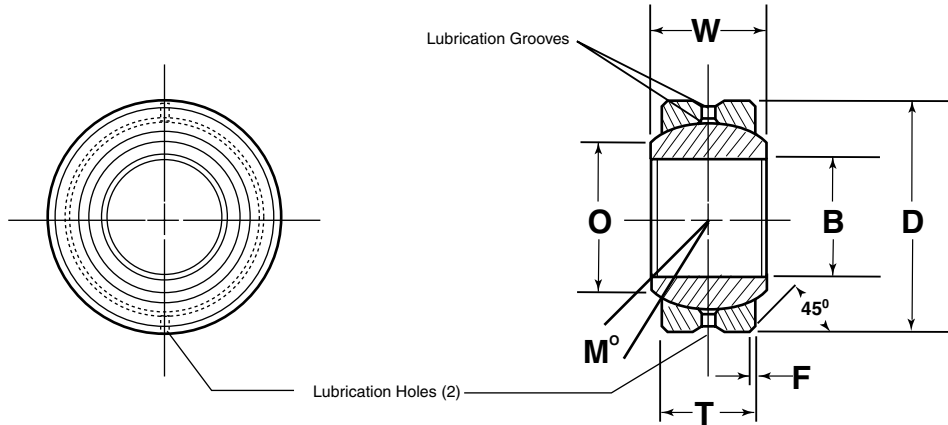

RSH HEAVY DUTY

PTFE Liner Available

RADIAL PART NO.	B	O	D	F	T	W	Ball Dia.	M°	HOUSING BORE	MAX. Static Radial Load	Approx. Weight (LBS)
	+0.0000 -0.0007	(REF.)	+0.0000 -0.0007	(REF.)	±.007	±.005	(REF.)	misalign angle	Recommended Alum. or Steel		
RSH-16	1.0000	1.360	2.0000	.035	.781	1.0000	1.687	9	1.9990 2.0000	69,500	.553
RSH-19	1.1875	1.610	2.3750	.035	.937	1.187	2.000	8.5	2.3740 2.3750	100,500	.937
RSH-20	1.2500	1.610	2.3750	.035	.937	1.187	2.000	8.5	2.3740 2.3750	100,500	.895
RSH-24	1.5000	1.860	2.7500	.035	1.094	1.375	2.312	8.5	2.7490 2.7500	135,000	1.358
RSH-28	1.7500	2.110	3.1250	.040	1.250	1.562	2.625	8	3.1240 3.1250	178,500	1.948
RSH-32	2.0000	2.360	3.5000	.040	1.375	1.750	2.937	8.5	3.4990 3.5000	221,000	2.640

Materials

BALL	RACE
Chrome Steel Heat Treated & Hard Chrome Plated	Low Carbon Steel Zinc Plated I.D. Oil Coated O.D.

Notes

- Basic radial allowable load is determined from 0.02% permanent set based on the nominal ball diameter per ARTC recommendation.
- Basic axial yield allowable load is 20% of basic radial yield allowable load.
- Standard radial clearance between ball and outer race .003 max. Special clearance can be furnished upon request.
- Dim "B" and "D" are concentric within .005 T. I. reading.
- Heavy duty bearings are available in other sizes and materials to suit your requirements.
- PTFE liners are available. Add suffix "T". Example: RSH-24T.
- Add "A" after material code designation if groove in I. D. and oil holes are required in ball. Example: RSH-20A.

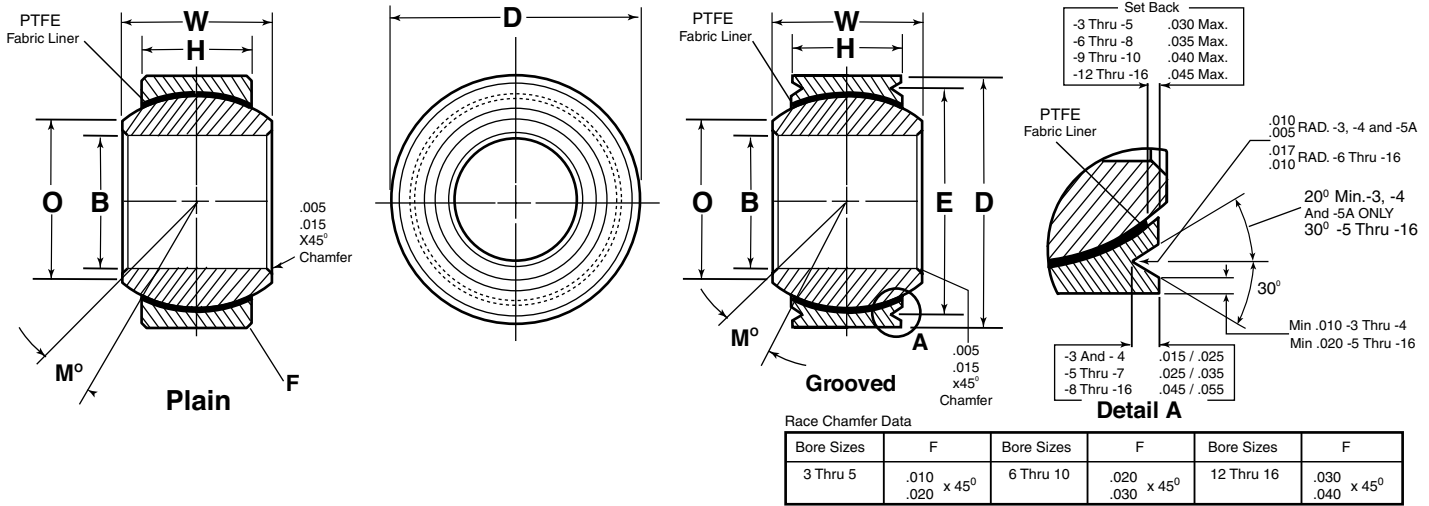

RPHT / RPHT-V NARROW/AEROSPACE

PTFE Lined

RADIAL PART NO.		B	D	W	H	E	O	Ball Dia.	M° mis align angle MIN.	Load Ratings (LBS)				Approx Weight (LBS)
										Static Limit		Dynamic Oscillating Radial Load	No Load Breakaway Torque (Inch Lbs)	
										Radial Load	Axial Load			
Plain	Grooved.	+ .0000 - .0005	+ .0000 - .0005	+ .000 - .002	± .005	+ .000 - .008	MIN.	(REF.)	MIN.					
RPHT-3	RPHT-3V	.1900	.5625	.281	.218	.500	.293	.406	10	3,975	150	1,500	.25 to 5	.020
RPHT-4	RPHT-4V	.2500	.6562	.343	.250	.594	.364	.500	10	6,040	430	3,320	.25 to 5	.020
RPHT-5	RPHT-5V	.3125	.7500	.375	.281	.650	.419	.562	10	8,750	700	5,460	.25 to 8	.030
-	RPHT-5AV	.3125	.7500	.375	.281	.660	.419	.562	10	8,750	700	5,460	.25 to 8	.030
RPHT-6	RPHT-6V	.3750	.8125	.406	.312	.712	.475	.656	9	10,540	1,100	6,600	.25 to 8	.040
RPHT-7	RPHT-7V	.4375	.9062	.437	.343	.806	.530	.718	8	13,200	1,400	8,050	.25 to 8	.050
RPHT-8	RPHT-8V	.5000	1.0000	.500	.390	.876	.640	.813	8	17,900	2,100	10,400	.25 to 8	.070
RPHT-9	RPHT-9V	.5625	1.0937	.562	.437	.970	.670	.875	8	23,200	3,680	13,000	.25 to 8	.090
RPHT-10	RPHT-10V	.6250	1.1875	.625	.500	1.063	.739	.968	8	30,500	4,720	16,450	.25 to 8	.120
RPHT-12	RPHT-12V	.7500	1.4375	.750	.593	1.313	.920	1.187	8	46,400	6,750	23,600	.25 to 8	.210
RPHT-14	RPHT-14V	.8750	1.5625	.875	.703	1.438	.980	1.312	8	62,200	9,350	30,250	.25 to 12	.270
RPHT-16	RPHT-16V	1.0000	1.7500	1.000	.797	1.626	1.118	1.500	9	82,200	12,160	38,000	.25 to 12	.390

Materials

BALL	RACE	LINER
440C (AMS-5630) CRES Heat Treated Hard Chrome Plated	17-4 PH AMS-5643 Heat Treated	PTFE Fabric Permanently Bonded to Race I. D.

Notes

1. Diameters "B", "D", & "E" are concentric within .003 T. I. R. on sizes -3 thru -5 and .005 T.I.R. on sizes -6 thru -16.
2. Finish: Ball Diameter- RHR 8 max. Bore, ball face, outer member dia-RHR 32 max. All other surfaces RHR 125 max.
3. Tolerances: Decimals + - .010, Angles: ± 1/2°.
4. Temperature range: -65° F to 325° F.
5. Bearings listed on this page conform to the materials dimensions, and configurations of MS- 14101 (Grooved) and MS- 14104 (Plain); however, Radial is not approved for procurement under that specification. Consult factory for additional information.



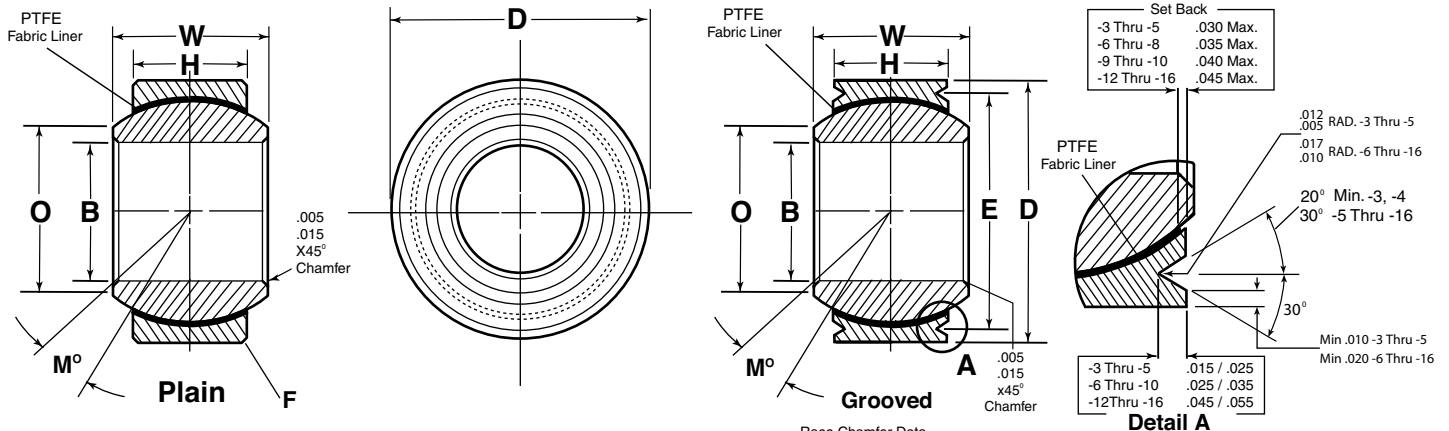

Race Chamfer Data

Bore Sizes	F	Bore Sizes	F	Bore Sizes	F
3 Thru 5	.010 .020 x 45°	6 Thru 10	.020 .030 x 45°	12 Thru 16	.030 .040 x 45°

RWT / RWT-V WIDE/AEROSPACE

PTFE Lined

RADIAL PART NO.		B	D	W	H	E	O	Ball Dia.	M° mis align angle MIN.	Load Ratings (LBS)				Approx Weight (LBS)
										Static Limit		Dynamic Oscillating Radial Load	No Load Breakaway Torque (Inch Lbs)	
Plain	Grooved.	+0.000 -0.005	+0.000 -0.005	+0.000 -0.002	±.005	+0.000 -0.008	MIN.	(REF.)	Radial Load	Axial Load				
RWT-3	RWT-3V	.1900	.6250	.437	.327	.563	.300	.531	15	2,500	1,770	4,900	.25 to 5	.031
RWT-4	RWT-4V	.2500	.6250	.437	.327	.563	.300	.531	15	5,500	1,770	4,900	.25 to 8	.031
RWT-5	RWT-5V	.3125	.6875	.437	.317	.625	.360	.593	14	9,400	1,640	6,050	.25 to 8	.035
RWT-6	RWT-6V	.3750	.8125	.500	.406	.712	.466	.687	8	13,700	2,630	8,310	.25 to 8	.060
RWT-7	RWT-7V	.4375	.9375	.562	.442	.837	.537	.781	10	20,700	3,650	11,750	.25 to 8	.080
-	RWT-7AV	.4375	.9062	.562	.442	.806	.537	.781	10	19,700	3,650	11,750	.25 to 8	.080
RWT-8	RWT-8V	.5000	1.0000	.625	.505	.900	.607	.875	9	21,400	4,970	14,950	.25 to 8	.100
RWT-9	RWT-9V	.5625	1.1250	.687	.536	1.025	.721	1.000	10	26,600	5,370	18,100	.25 to 8	.135
RWT-10	RWT-10V	.6250	1.1875	.750	.567	1.087	.747	1.062	12	29,000	6,130	20,250	.25 to 8	.160
RWT-12	RWT-12V	.7500	1.3750	.875	.630	1.251	.845	1.250	13	37,000	7,730	26,200	.25 to 8	.240
RWT-14	RWT-14V	.8750	1.6250	.875	.755	1.501	.995	1.375	6	65,200	10,800	33,600	.25 to 12	.350
RWT-16	RWT-16V	1.0000	2.1250	1.375	1.005	2.001	1.269	1.875	12	104,000	19,300	56,250	.25 to 12	.970

Materials

BALL	RACE	LINER
440C (AMS-5630) CRES Heat Treated Hard Chrome Plated	17-4 PH AMS-5643 Heat Treated	PTFE Fabric Permanently Bonded to Race I. D.

Notes

- Diameters "B", "D", & "E" are concentric within .003 T. I.R. on sizes -3 thru -5 and .005 T. I.R. on sizes -6 thru -16.
- Finish: Ball Diameter- RHR 8 max. Bore, ball face, outer member dia-RHR 32 max. All other surfaces RHR 125 max.
- Tolerances: Decimals + - .010, Angles: ± 1/2°.
- Temperature range: -65° F to 325° F.
- Bearings listed on this page conform to the materials/dimensions, and configurations of MS-14102 (Plain) and MS-14103 (Grooved) however, Radial is not approved for procurement under that specification. Consult factory for additional information.



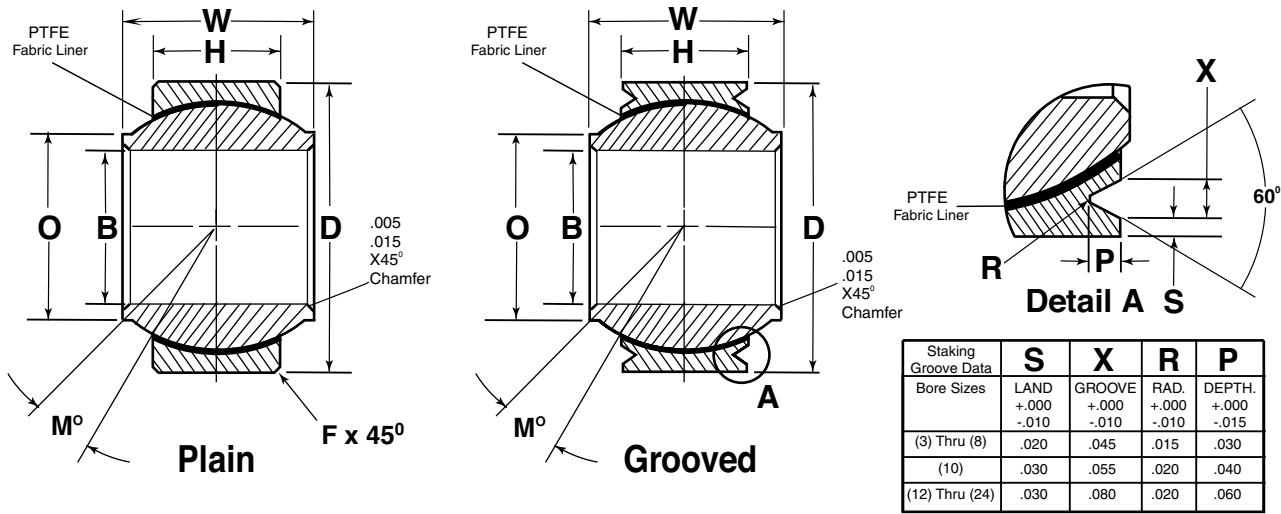

RYT / RYT-V

High Misalignment/PTFE Lined

RADIAL PART NO.		B	D	W	H	O	Ball Dia.	F	M° mis align angle (REF.)	Load Ratings (LBS)				Approx. Weight (LBS)
										Static Limit		Dynamic Oscillating Radial Load	No Load Breakaway Torque (Inch Lbs)	
										Radial Load	Axial Load			
Plain	Grooved.	+ .0000 - .0005	+ .0000 - .0005	+ .000 - .005	± .005	(REF.)	(REF.)	+ .000 - .010						
RYT-3	RYT-3V	.1900	.5625	.500	.210	.319	.437	.020	15	4,100	350	2,100	.5 to 5	.018
RYT-4	RYT-4V	.2500	.7400	.593	.255	.390	.593	.022	24	7,100	750	3,800	1 to 5	.036
RYT-5	RYT-5V	.3125	.6875	.625	.255	.418	.593	.022	20	9,000	750	3,800	1 to 5	.025
RYT-6	RYT-6V	.3750	.9060	.813	.345	.512	.781	.032	23	16,000	2,000	7,200	1 to 5	.068
RYT-7	RYT-7V	.4375	1.0000	.875	.345	.618	.875	.032	22	19,300	2,000	8,100	1 to 5	.095
RYT-8	RYT-8V	.5000	1.1250	.937	.401	.730	1.000	.032	20	26,100	3,200	10,900	1 to 5	.159
RYT-10	RYT-10V	.6250	1.3750	1.200	.567	.856	1.250	.032	20	44,500	7,000	20,000	1 to 5	.245
RYT-12	RYT-12V	.7500	1.5625	1.280	.620	.970	1.375	.044	18	54,800	8,700	24,200	1 to 6	.315
RYT-14	RYT-14V	.8750	1.7500	1.400	.625	1.140	1.531	.044	18	65,800	8,850	27,600	2 to 8	.430
RYT-16	RYT-16V	1.0000	2.1250	1.875	.835	1.278	1.875	.044	21	108,000	15,900	45,600	2 to 8	.831
RYT-20	RYT-20V	1.2500	2.5000	1.875	1.005	1.523	2.250	.044	21	158,000	23,000	66,600	3 to 15	1.318
RYT-24	RYT-24V	1.5000	3.0000	2.250	1.175	1.800	2.672	.044	21	220,000	32,000	93,200	3 to 15	2.223

Materials

BALL	RACE	LINER
440C CRES Heat Treated Hard Chrome Plated	Stainless Steel Heat Treated	PTFE Fabric Permanently Bonded to Race I. D.

Notes

1. Diameters "B" & "D" are concentric within .005 T. I. R.
2. Temperature range: -65° F to +325° F.



BEARING INTERCHANGE LIST

RADIAL	AURORA	NHBB	NATIONAL	FK	HEIM	MORSE
RM	MM	HAMR	MTSM	JM	HM	TRE
RF	MW	HAFR	MTSF	JF	HF	TR
RMX	KM					
RFX	KW					
RM-H	AM	HAMRX	TSMX	JMX	BHM	ARE
RF-H	AW	HAFRX	TSFX	JFX	BHF	AR
XRM	XM	AXM	RM	RSM		
XRM-H	XAM	XAMX	RMX	RSMX	HMX	
RM-T	MM-T	AMRT	MTSM-T	JM-T	HME	TRE-T
RF-T	MW-T	AFRT	MTSF-T	JF-T	HFE	TR-T
RM-TH	AM-T		TSMX-T	JMX-T		
RF-TH	AW-T		TSFX-T	JFX-T		
XRM-T	XM-T		RM-T	RSMX-T		
XRM-TH	XAM-T		RXM-T	RSMX-T		
REMX		AMRX-F	BMX-Z		HMX	ARE-20N
REM-TH-5/6	ASM-T	ANM/ARTE	SSAM-T		ME	
REF-TH-5/6	ASW-T	ANF/ART	SSAF-T		FE	
XRM-TH-6		ARHT-ECR	SSHM-T			
XRF-TH-6		ARHT-CR	SSHF-T			
RMYT-H	HXAM-T	ARYT-E				
RMYT-HSS	HXAM-T	ARYT-ECR				
CRS	COM		COM			COM
R					LHB	SBG
RB						
RS					LHA	SBG-S
R-SS					LHSS	SBG-SS
RCR					COS	COR
RSH	HCOM					BH-LS
RW/RW-V		ABW/ABW-V				
RPHT/RPHT-V	ANC-T/ANC-TG	ABT-ABT-V	NSSB/NSSB-V		NE/NEG	NE/NEG
RWT/RWT-V	AWC-T/AWC-TG	ADW/ADW-V	WSSB/WSSB	FKSST-1	WE/WEG	WE/WEG
RYT/RYT-V	HAB-T	ABYT/ABYT-V				

Note: The above interchanges are approximate and not intended to indicate that all manufacturers are functionally interchangeable in all applications.



203-744-0323 800-377-1937 Fax: 203-744-1691

LOAD DEFINITIONS

RADIAL LOAD—A load applied normal to the bearing bore axis.

AXIAL LOAD—A load applied along the bearing bore axis.

STATIC RADIAL LIMIT LOAD—That static load required to produce a specified permanent set in the bearing structure. It will vary for a given size as a function of configuration. It may also be pin limited or it may be limited as a function of body restraints, as in the case of a rod end bearing.

STATIC RADIAL ULTIMATE LOAD—That load that can be applied to a bearing without fracturing the ball, race or rod end eye. The ultimate load rating is usually but not always 1.5 times the limit load.

STATIC AXIAL LIMIT LOAD—That load that can be

applied to a bearing to produce a specified permanent set in the bearing surface.

STATIC AXIAL ULTIMATE LOAD—That load that can be applied to a bearing without separating the ball from the race. The ultimate load rating is usually but not always 1.5 times the limit load.

AXIAL PROOF LOAD—That axial load that can be applied to a mounted spherical bearing without impairing the integrity of the bearing mounting or bearing performance. It is always less than the static axial limit load.

OSCILLATING RADIAL LOAD—A unidirectional load producing a specified maximum amount of wear when the bearing is oscillated at a specific frequency and amplitude.

FORMULAE FOR DETERMINING MISALIGNMENT OF ROD END & SPHERICAL BEARINGS

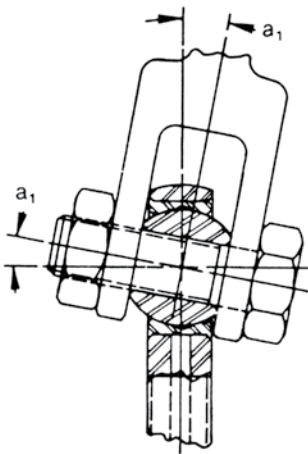

FIGURE 1

$$a_1 = \sin^{-1} \frac{W}{D} - \sin^{-1} \frac{H}{D}$$

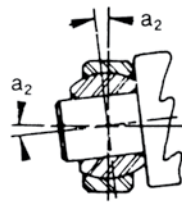

FIGURE 2

$$a_2 = \sin^{-1} \frac{W}{A} - \sin^{-1} \frac{H}{A}$$

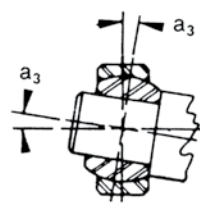

FIGURE 3

$$a_3 = \sin^{-1} \frac{W}{E} - \sin^{-1} \frac{H}{E}$$

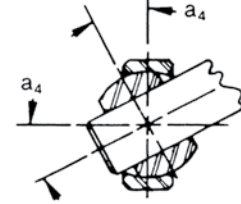

FIGURE 4

$$a_4 = \cos^{-1} \frac{B}{E} - \sin^{-1} \frac{H}{E}$$

Reference Letters

- B - Ball Bore
- C - Outer Race Chamfer
- D - Head Diameter or Outer Race Diameter
- E - Ball Diameter
- H - Housing Width
- A - $\sqrt{(D - 2C)^2 + H^2}$
- W - Ball Width

The misalignment angle of a rod or spherical bearing refers to the angle between the ball centerline and the outer member centerline when the ball is misaligned to the extreme position allowed by the clevis or shaft design, as applicable.

Figures 1 through 4 illustrate varying types of bearing misalignment and a formula for calculating each.



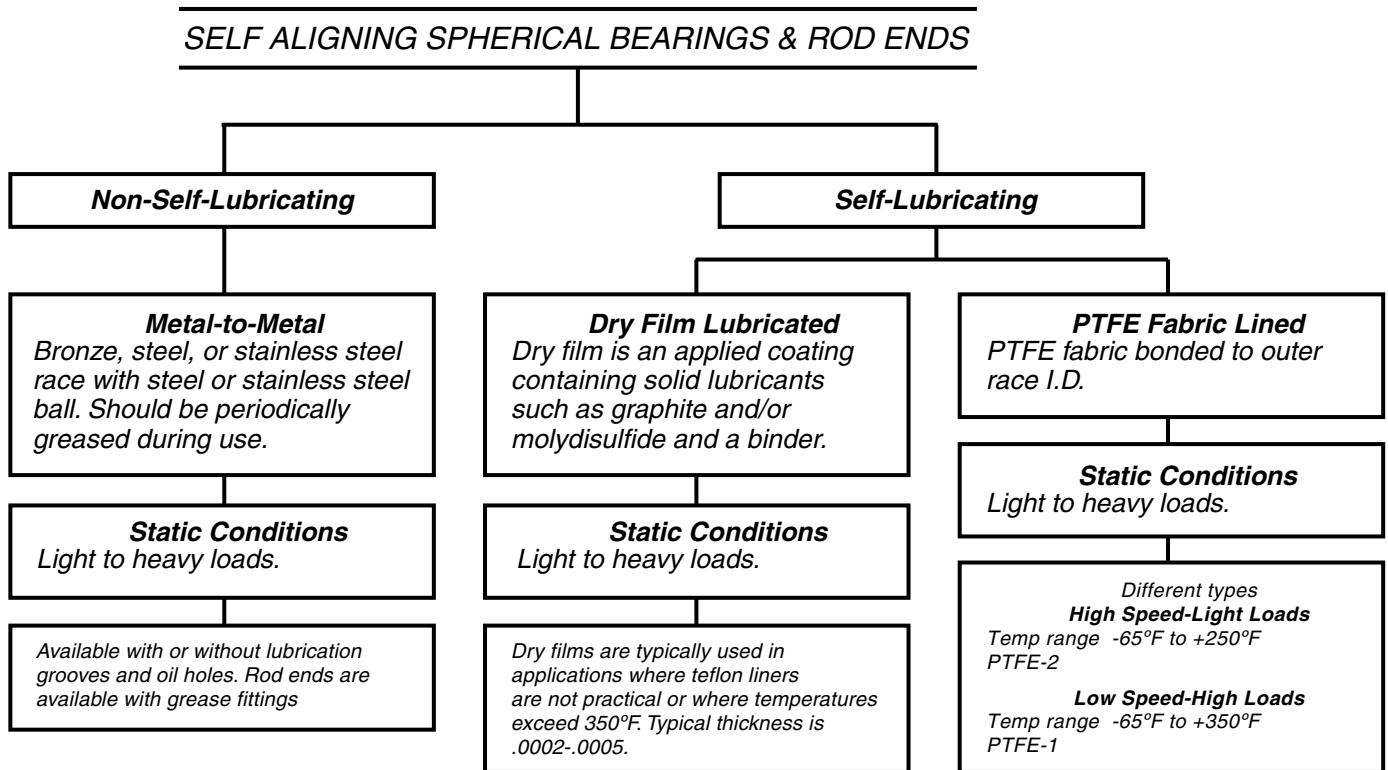

GENERAL INFORMATION

Radial Bearing Products are manufactured in accordance with the highest prevailing standards within the bearing industry. All of the manufacturing materials and processes are certifiable to military, Federal or customer specifications as required. Some of the standards utilized in our processes follow:

Quality Management System
Heat Treatment
Magnetic Inspection
Penetrant Inspection
Zinc Plate
Cadmium Plate
Chrome Plate
Anodize
Chemical Film
Passivation
Dry Film

Registered to **AS9100/ISO 9001** (Design Included)
SAE-AMS-H-6875
ASTM-E1444
ASTM-E1417
ASTM-B633
SAE-AMS-QQP-416
SAE-AMS-QQ-C-320
Mil-A-8625
Mil-C-5541
Mil-S-5002
Mil-PRF-46010

RADIAL BEARING CORPORATION



203-744-0323 • 800-377-1937 Fax: 203-744-1691
21 Taylor St. Danbury, CT 06810 U.S.A.
email: sales@radialbearing.com
website: www.radialbearing.com

DISTRIBUTED BY: